

TYPICAL SECTION LEGEND

REF. NO.	ODOT ITEM	DESCRIPTION
①	609	ODOT TYPE 2 (6" VERTICAL) PORTLAND CEMENT CONCRETE COMBINATION CURB & GUTTER, INCLUDING CUTTING AND SEALING ALL CONTRACTION JOINTS
②	304	6" AGGREGATE BASE (SLAG NOT ALLOWED)
③	408 AND 301	PRIME COAT @ 0.15 TO 0.35 GAL./S.Y. (RATE TO BE FIELD DETERMINED) 5" BITUMINOUS AGGREGATE BASE
④	407 AND 441	TACK COAT @ 0.10 GAL./S.Y. 2" ASPHALT CONCRETE SURFACE COURSE, TYPE 1
⑤	605	4" DIAMETER PERFORATED UNDERDRAIN WITH WASHED FILTER AGGREGATE No. 8 (SEE DETAIL, THIS SHEET)
⑥	611	6" DIA. SANITARY CONNECTION
⑦	611	6" DIA. STORM CONNECTION
⑧	SPEC	1" DIA. WATER CONNECTION
⑨	SPEC	WATER CONNECTION SHUTOFF BOX
⑩	204	SUBGRADE COMPACTION AND PROOF-ROLLING

* NOTE:
THE CONTRACTOR SHALL MARK THE ENDS OF ALL CONNECTIONS, RISERS AND CURB BOXES BY INSTALLING 2" x 2" STAKES EXTENDING A MINIMUM OF 3' ABOVE GRADE AND EXTENDED DOWN TO THE CAP.
CAPS AND MARKERS SHALL BE COLOR CODED: STORM—GREEN, SANITARY—RED, & WATER—BLUE.

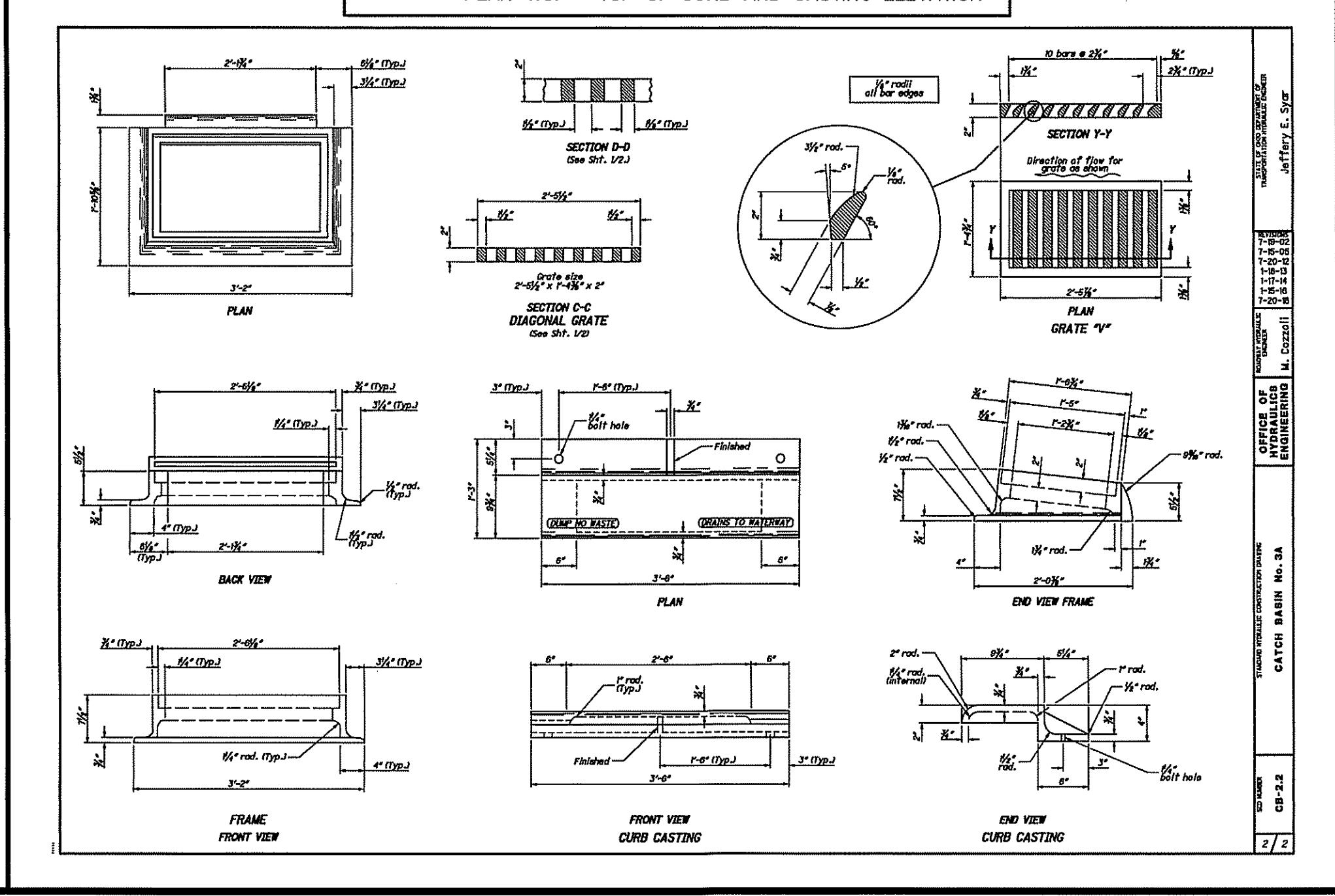
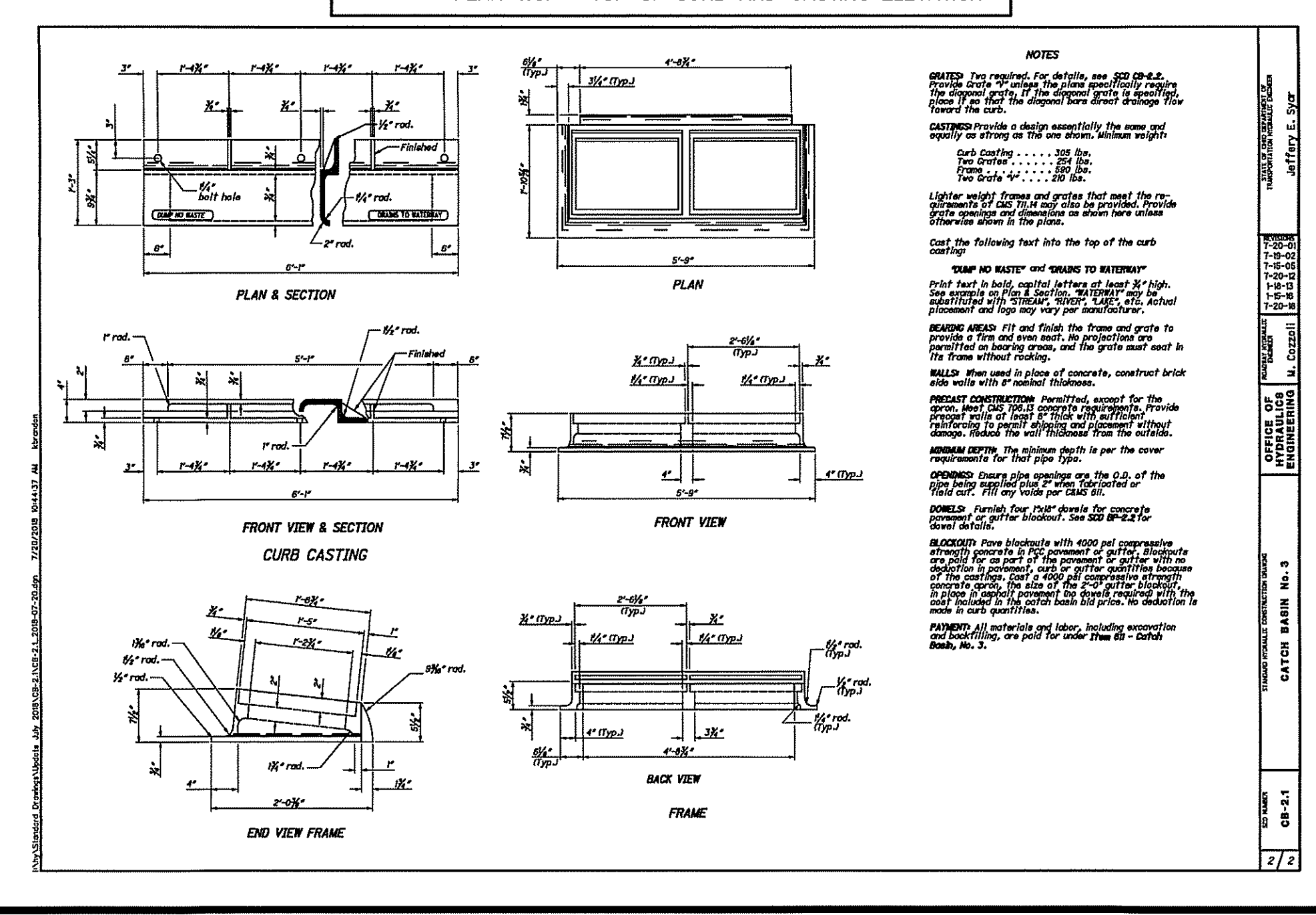
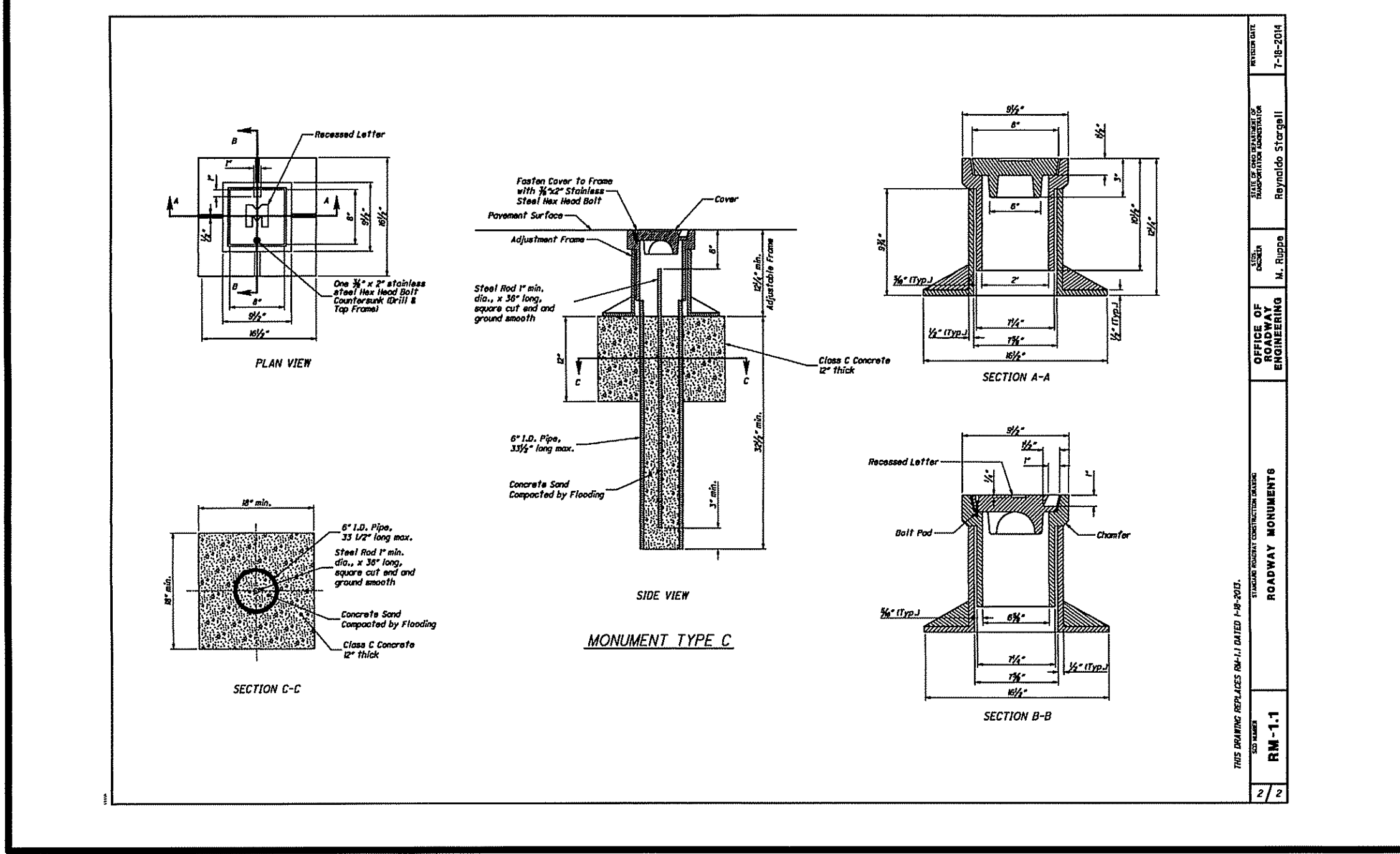
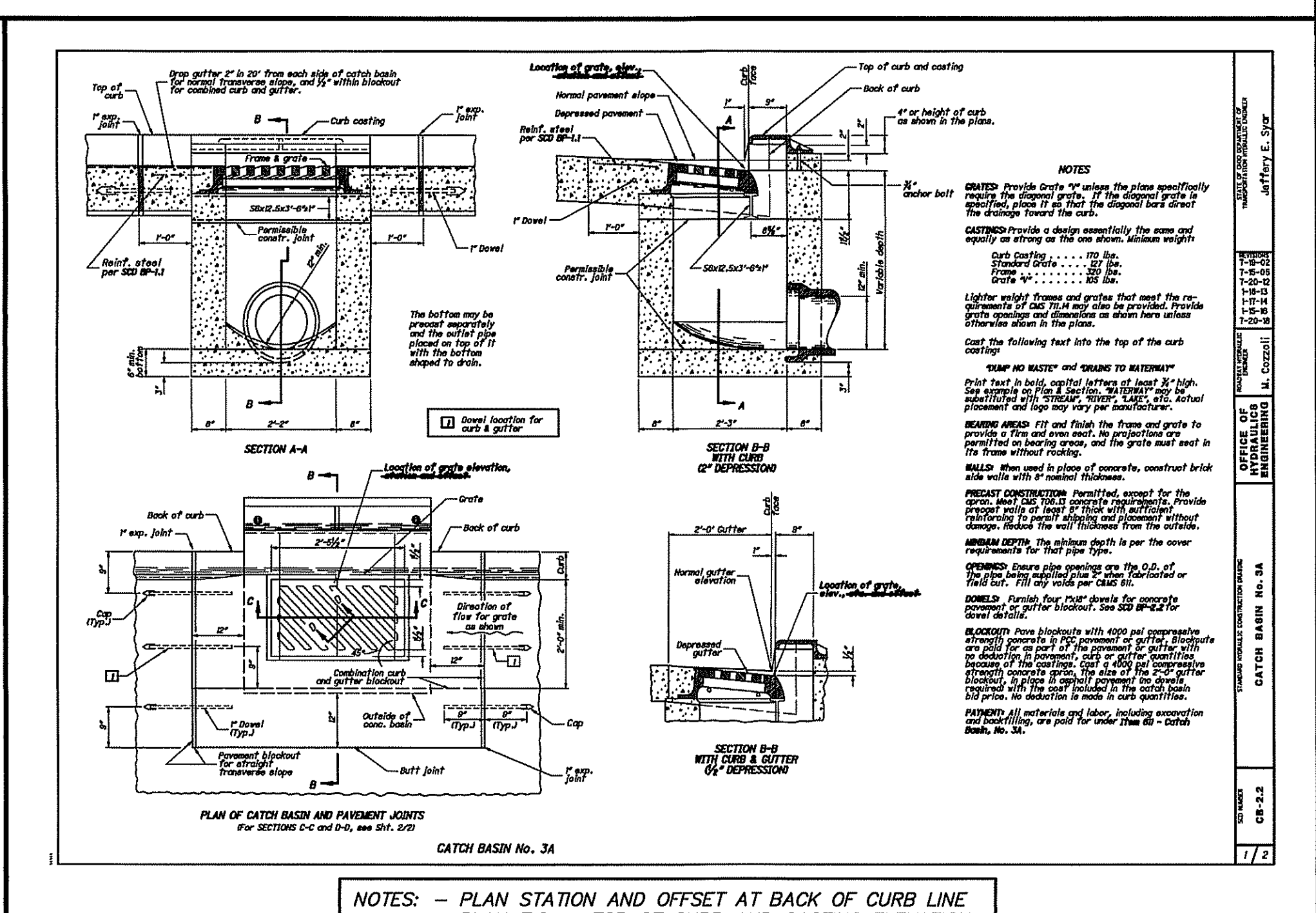
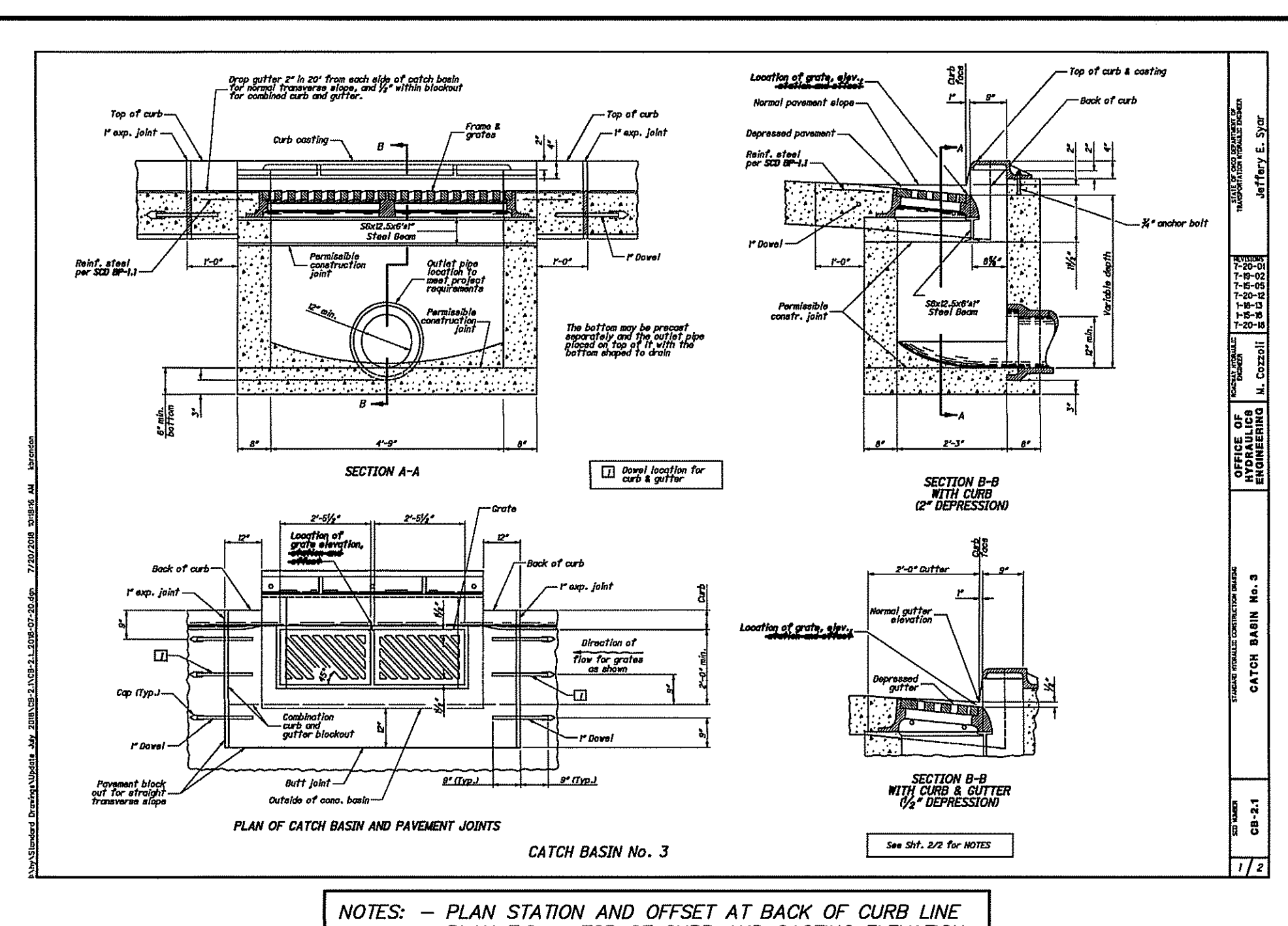
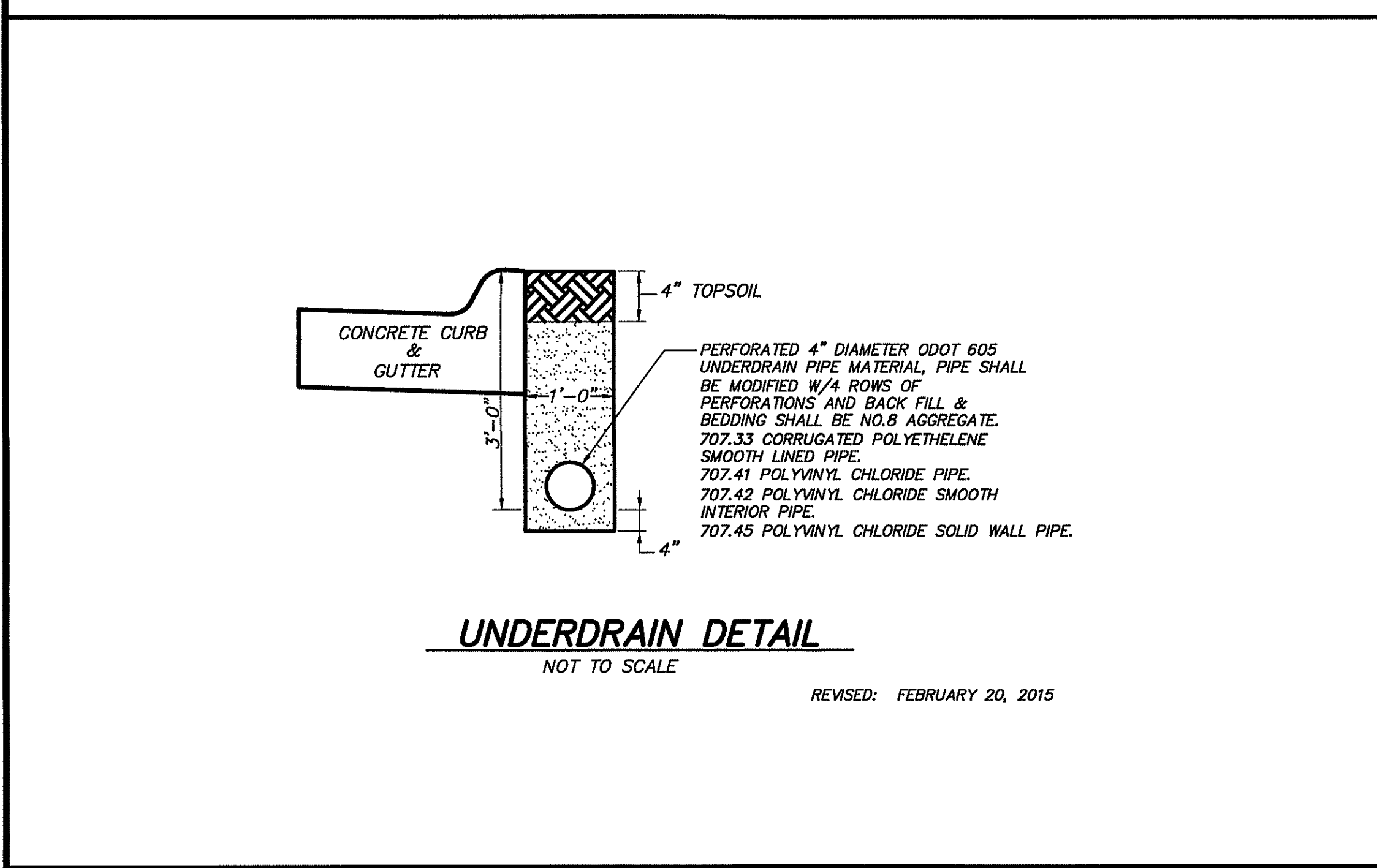

REVISIONS
7/18 PER S.C.E.

TYPICAL SECTION & DETAILS
MOTTLE RESERVE SUBDIVISION
PHASES 1 & 2
SAGAMORE HILLS TOWNSHIP
SUMMIT COUNTY, OHIO

DONALD G. BOHNING & ASSOCIATES, INC.
 CIVIL ENGINEERING & SURVEYING
 7975 HUB PARKWAY • VALLEY VIEW, OHIO 44125
 PHONE: (216) 842-1130 FAX: (216) 842-1132
 A LICENSED PROFESSIONAL ENGINEER UNDER REG. NO. 9702008 3/17/04

GRAPHIC SCALE
 0' 10' 20'
 HORIZ. SCALE
 1" = 20'
 VERT. SCALE

 DRN S.W. D.G.
 DATE
 MAY, 2018
 ORDER NO.
 3750-10

13
21