

- LEGEND**
- ① ODOT ITEM 448 - 1 1/2" ASPHALT CONCRETE SURFACE COURSE, TYPE 1, PG 64-22
 - ② ODOT ITEM 301 - 5" ASPHALT CONCRETE BASE
 - ③ ODOT ITEM 304 - 6" AGGREGATE BASE, 703.17 MATERIAL
 - ④ ODOT ITEM 204 - SUBGRADE COMPACTION AND PROOF ROLLING
 - ⑤ ODOT ITEM 609 - 2'-0" CURB & GUTTER W/VERTICAL CURB
 - ⑥ ODOT ITEM 608 - 4" THICK CONCRETE SIDEWALK WITH 2" AGGREGATE BASE (6" THICK CONCRETE WITH 2" AGGREGATE BASE AT DRIVEWAYS)
 - ⑦ ODOT ITEM 407 - TACK COAT, 0.16 GAL. PER S.Y.
 - ⑧ ODOT ITEM 408 - PRIME COAT, 0.40 GAL. PER S.Y.
 - ⑨ ODOT ITEM 605 - 4" DIA. PERFORATED UNDERDRAIN WITH GRANULAR FILTER AGGREGATE NO. 8
 - ⑩ ODOT ITEM 653 - 4" TOPSOIL OR ONSITE MATERIAL
 - ⑪ ODOT ITEM 659 - SEEDING AND MULCHING, CLASS 1

(SUMMIT COUNTY ENGINEER)
4" UNDERDRAIN
 NOT SCALE

4" TOPSOIL
 CONCRETE CURB & GUTTER
 PERFORATED 4" DIAMETER ODOT 605 UNDERDRAIN PIPE MATERIAL PIPE SHALL BE MODIFIED W/4 ROWS OF PERFORATIONS AND BACK FILL & BEDDING SHALL BE NO.8 AGGREGATE.
 707.33 CORRUGATED POLYETHYLENE SMOOTH LINED PIPE.
 707.41 POLYVINYL CHLORIDE PIPE.
 707.45 POLYVINYL CHLORIDE SOLID WALL PIPE.
 707.42 POLYVINYL CHLORIDE SMOOTH INTERIOR PIPE.

NOTE: CRACK CONTROL SHALL BE AT FIFTEEN FOOT (15') INTERVALS AND SCORE MARKS SHALL BE AT FIVE FOOT (5') INTERVALS. CONSTRUCTION SHALL BE IN ACCORDANCE WITH O.D.O.T. ITEM 608. PRIOR TO THE START OF SIDEWALK CONSTRUCTION THE SUBGRADE MUST BE INSPECTED AND APPROVED BY C.O.S.E. PERSONNEL ANY SETTLEMENT OR DEFICIENT AREAS IDENTIFIED BY C.O.S.E. SHALL BE REPAIRED BY A METHOD ACCEPTABLE TO C.O.S.E. THE REPAIRED AREAS WILL BE SUBJECT TO COMPACTION TESTING AND APPROVAL BY C.O.S.E. PRIOR TO THE START OF SIDEWALK CONSTRUCTION.

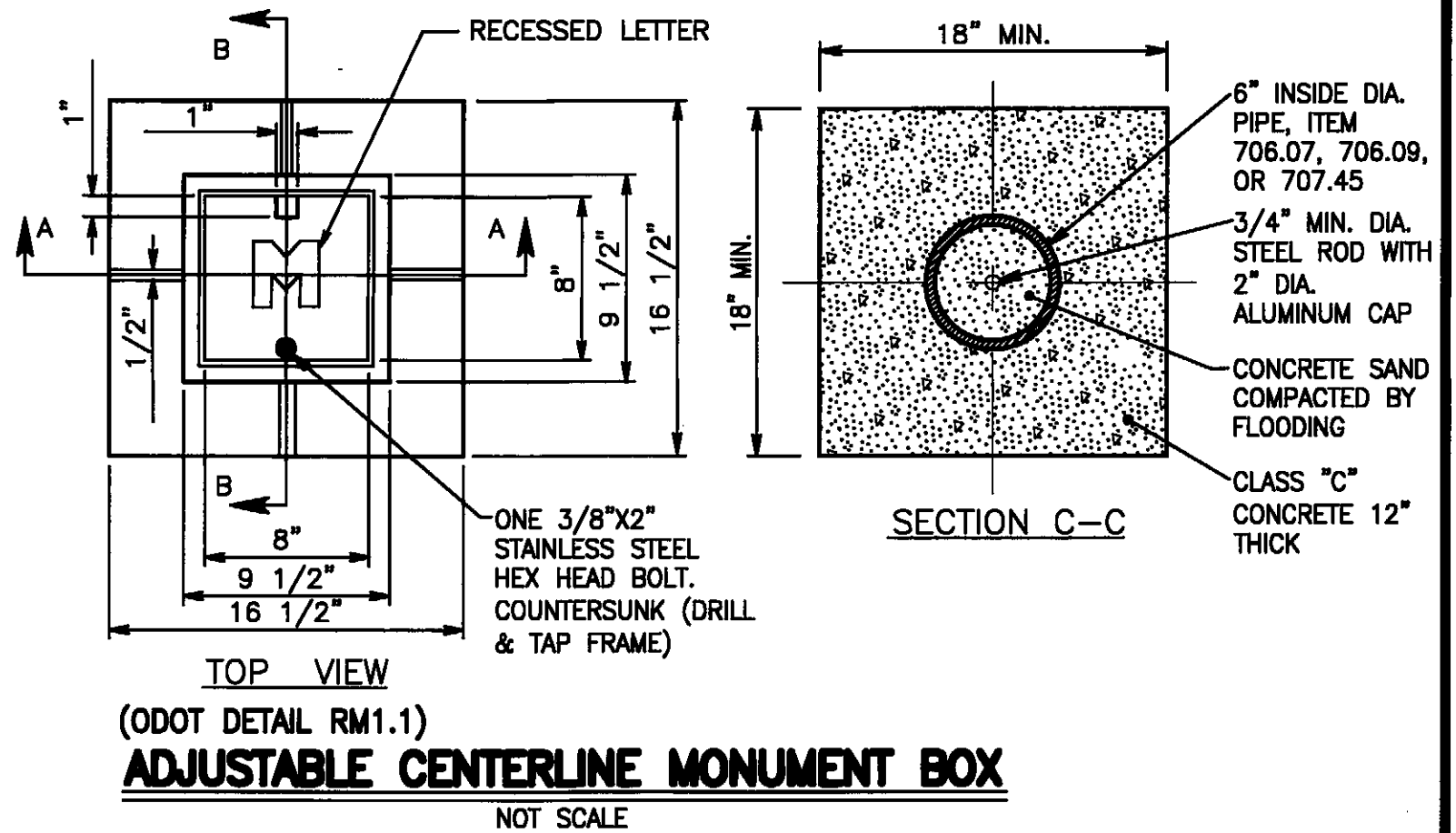
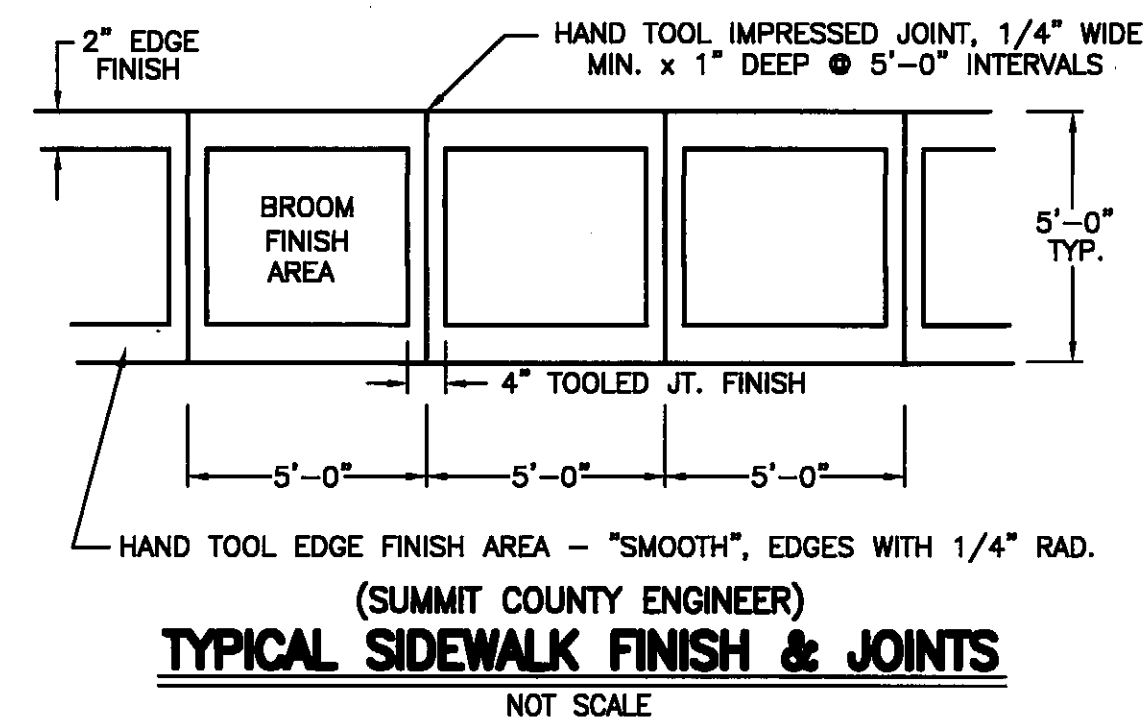
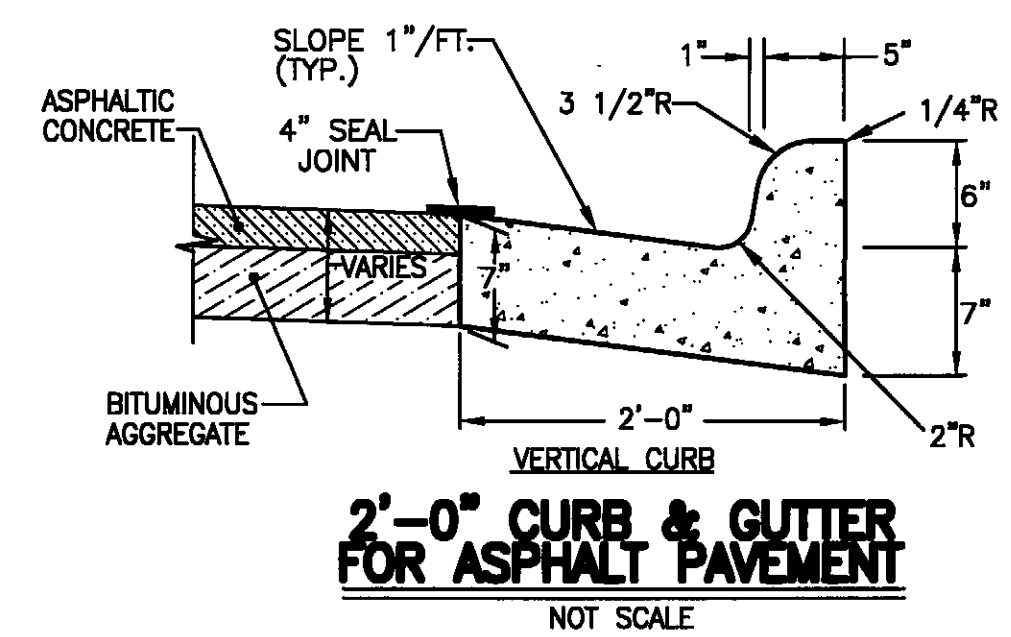
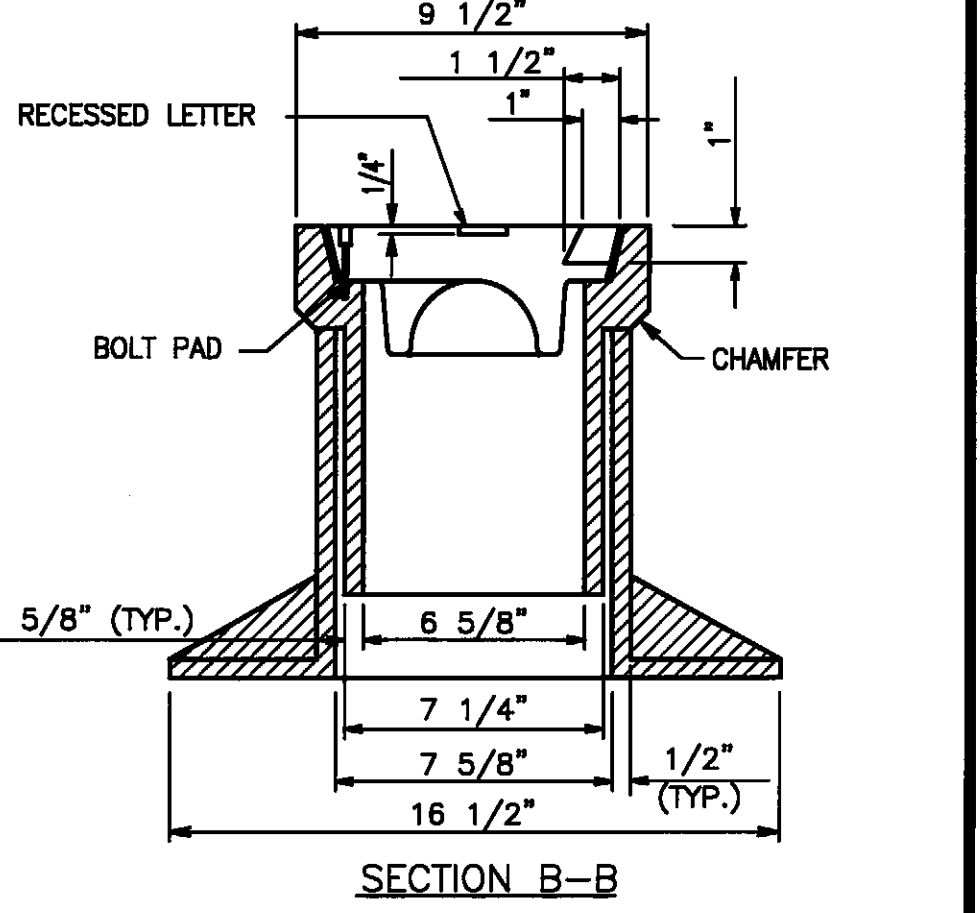
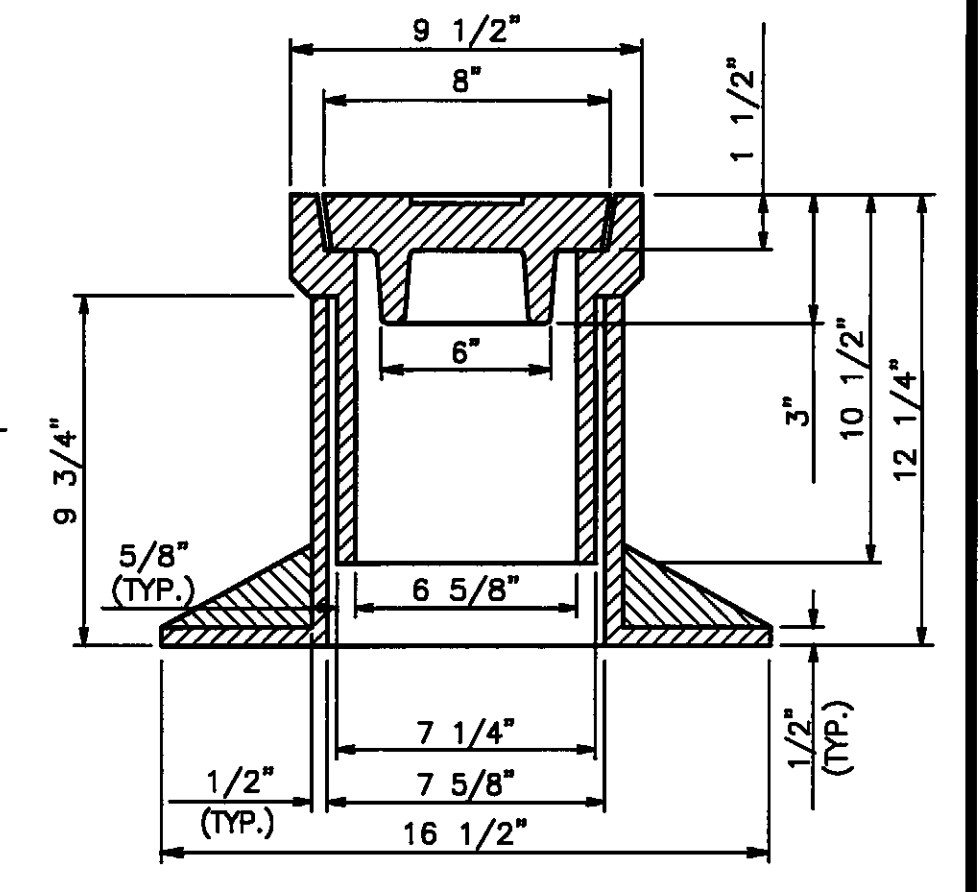
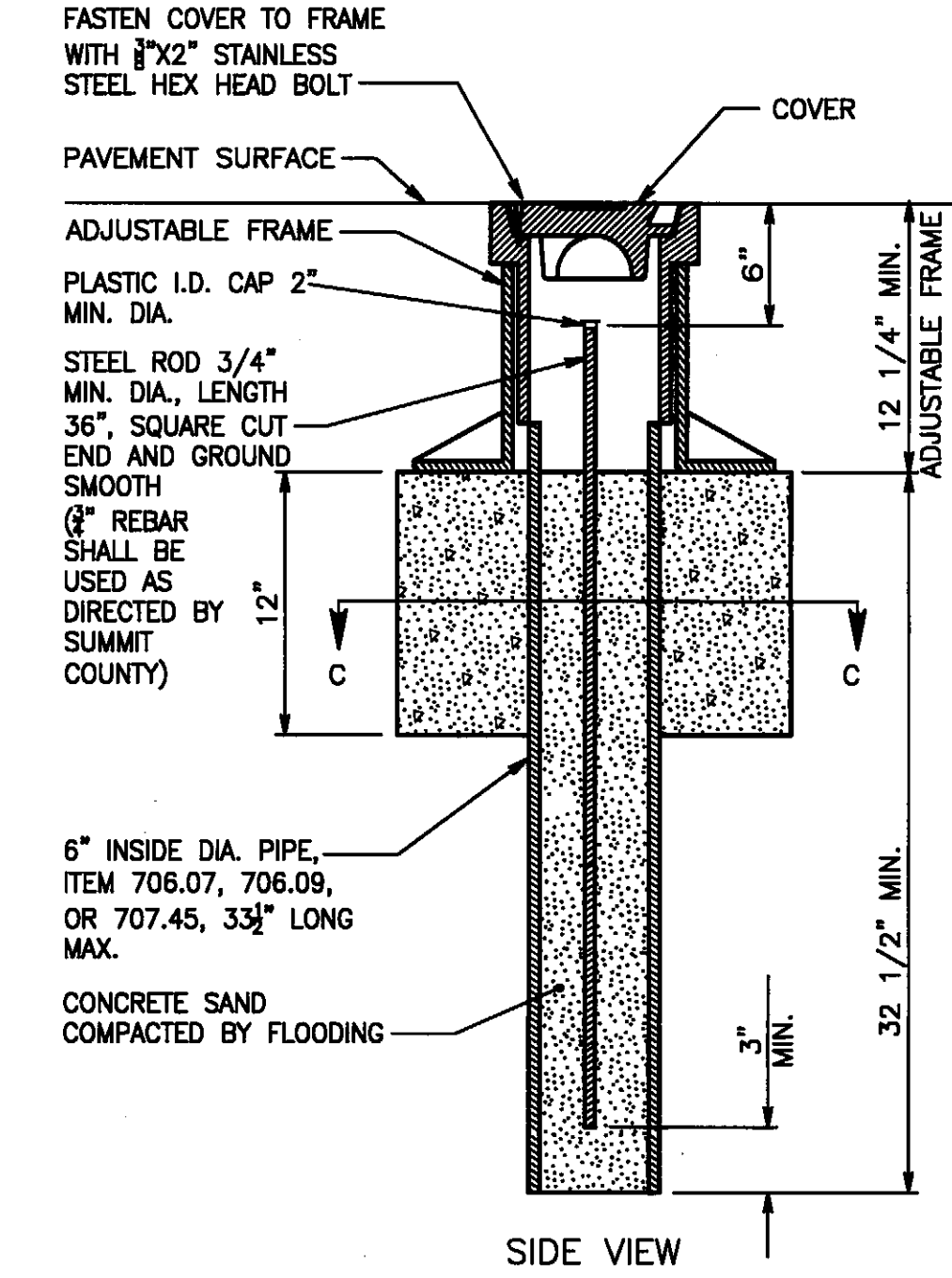
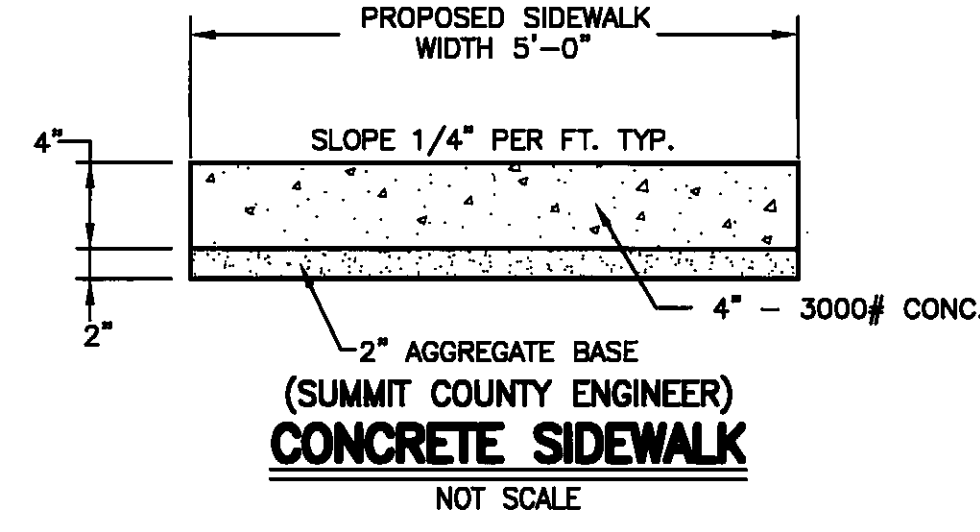

JOB NO 12289F	SCALE AS NOTED
DRAWN BY MJD	CHECKED BY CJO
DWG NAME 12289C-det	DATE SEPTEMBER, 2014

HILLSIDE ESTATES - PHASE 4
TYPICAL SECTION AND DETAILS
 TOWNSHIP OF COPLEY, COUNTY OF SUMMIT, STATE OF OHIO

NEFF
 & ASSOCIATES
 Civil Engineers + Landscape Architects + Planners + Surveyors
 6405 York Road | Parma Heights, Ohio 44130
 Tel: 440.884.3100 | Fax: 440.884.3104

REV NO	DATE	DESCRIPTION	BY
3	02/27/15	REV. PER COSE & SUMMIT SWCD	CJO
2	11/17/14	REV. PER COSE, DOES, AKRON WTR.	CJO
1	09/15/14	ORIGINAL SUBMITTAL	CJO

SHEET NO.
C7.0