

ODOT SPECIFICATION REFERENCE

- ① 1 1/2" ASPHALT CONCRETE/SURFACE COURSE (SEE TABLE 1)
- ② DEPTH VARIES BITUMINOUS AGGREGATE BASE (SEE TABLE 1)
- ③ ITEM 304 - AGGREGATE BASE, 703.17 MATERIAL (SEE TABLE 1 FOR THICKNESS)
- ④ ITEM 605 - 4" DIA. PERFORATED UNDERDRAIN WITH GRANULAR FILTER AGGREGATE NO. 8. (SEE DETAIL)
- ⑤ ITEM 608 - 4" THICK CONCRETE SIDEWALK, 6" AT DRIVEWAYS WITH 2" AGGREGATE BASE (SEE DETAIL)
- ⑥ ITEM 663 - TOPSOIL (T = 4" TYP.) OR ON-SITE MATERIAL
- ⑦ ITEM 659 - SEEDING AND MULCHING "CLASS 1"
- ⑧ ITEM 204 - "SUBGRADE COMPACTION & PROOF ROLLING"
- ⑨ ITEM 609 - 2" CONCRETE CURB & GUTTER
- ⑩ ITEM 407 - TACK COAT @ 0.075 GAL./S.Y.



Reg. No.: 61709

Dunham Land Properties Inc.
 756 Ravenhill Drive
 Sagamore Hills, OH 44067
 Paul Karnow
 Ph.# (330) 468-2892
 Fax# (330) 468-2892

NOTE: ITEMS 1&2 SHALL MEET CURRENT ODOT CONSTRUCTION & MATERIAL SPECIFICATIONS W/ANY AMMENDMENTS BY COSE.

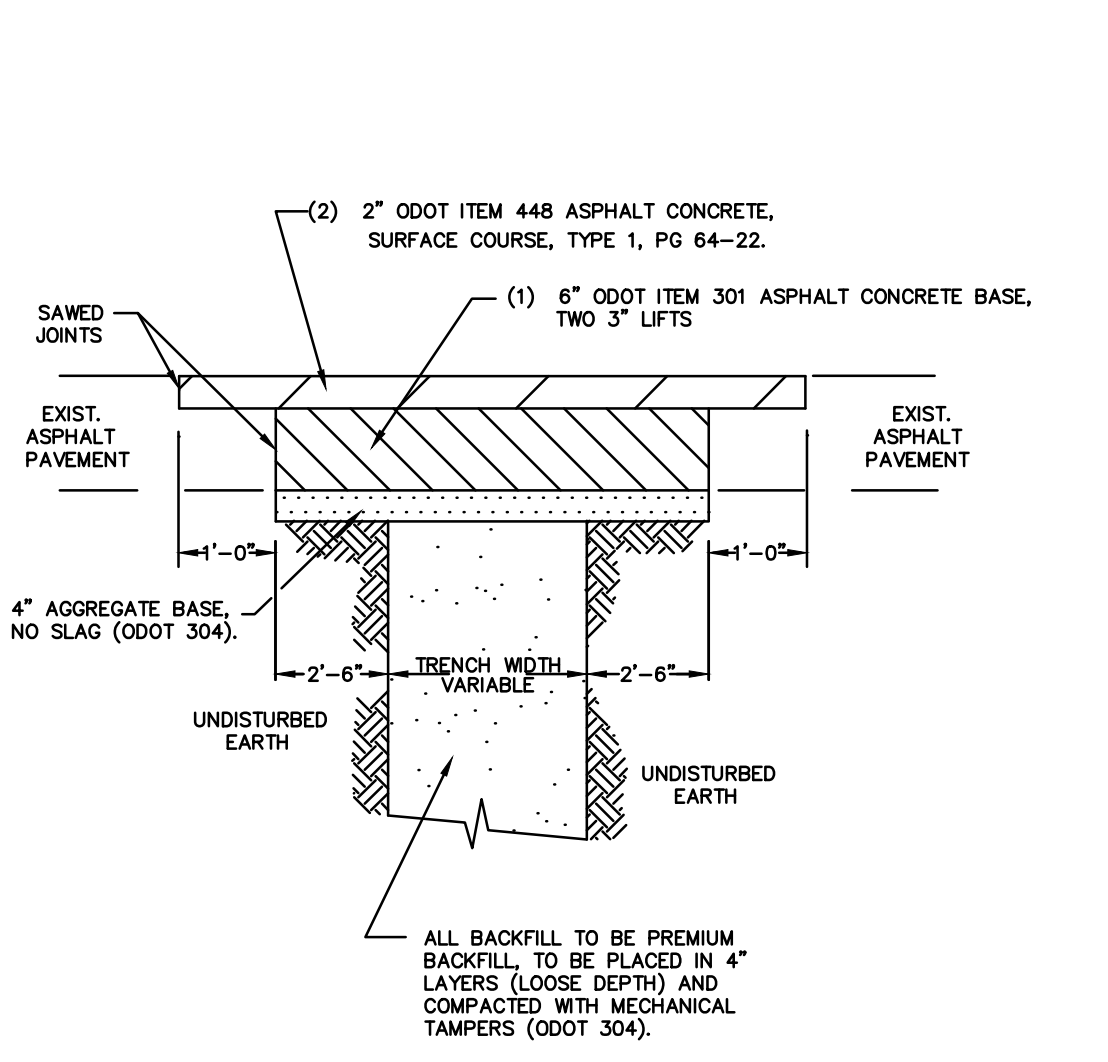

PAVEMENT OPENING DETAIL FOR FLEXIBLE PAVEMENT
 REFERENCE ONLY NOT TO SCALE

TABLE 1: Minimum Road Construction Standards for Subdivisions

ROAD CLASS	PAVEMENT WIDTH		PAVEMENT THICKNESS							
	CURBS ***	NO CURBS	PLAIN CONCRETE	ASPHALT CONCRETE AGGREGATE BASE		FULL DEPTH ASPHALT				
			304 AGG.	ITEM 452	304 AGG.	BIT. AGG. BASE	SURF. COURSE	304 AGG.	BIT. AGG. BASE	SURF. COURSE
1. Major Arterial	28'	24**	3"	8"	6"	8"	2"	3"	9"	2"
2. Collector Roads	28'	24**	3"	8"	6"	6"	1 1/2"	3"	7 1/2"	1 1/2"
3. Marginal Access Roads/ Parallel Streets	28'	24**	3"	7"	6"	6"	1 1/2"	3"	7 1/2"	1 1/2"
4. Local Roads										
a. Residential Light Traffic	24'	22'	3"	7"	6"	5"	1 1/2"	3"	6"	1 1/2"
b. Residential Medium Traffic	28'	24'	3"	7"	6"	5"	1 1/2"	3"	7"	1 1/2"
c. Commercial and Indust. Park	30'	28'	3"	9"	6"	7"	1 1/2"	3"	8"	1 1/2"

- A Major Arterial connects significant generators of traffic and accommodates high traffic volumes for through movements at relatively high speeds. The Typical Section is a minimum standard and the County of Summit Engineer reserves the right to require modifications to the Typical Section based on the Average Daily Traffic for the proposed Major Arterial.
 - A Collector Road connects local roads with arterial roads.
 - A Parallel Street/Marginal Access Road is parallel to a freeway or arterial road and provides access to local roads.
 - A Residential Light Traffic Road is a dead end road serving less than 25 sublots such as rural residential development.
 - A Residential Medium Traffic Road is a dead end road serving more than 25 sublots, or a road passing through a residential area but out of line of main through traffic such as urban single and multi-family development.
 - Commercial and Industrial Park Roads are roads in subdivisions having commercial and/or industrial enterprises served by trucks.
 - In case of question, the County of Summit Engineer will decide on the road class for construction purposes.
 * Indicates that these roadways require a 4' crushed aggregate base.
 ** Indicates that these roadways require a 2' crushed aggregate base.
 *** Pavement width for curbed section means back of curb to back of curb.
 Items 1 & 2 shall meet Current ODOT Construction & Material Specifications with any amendments by COSE.

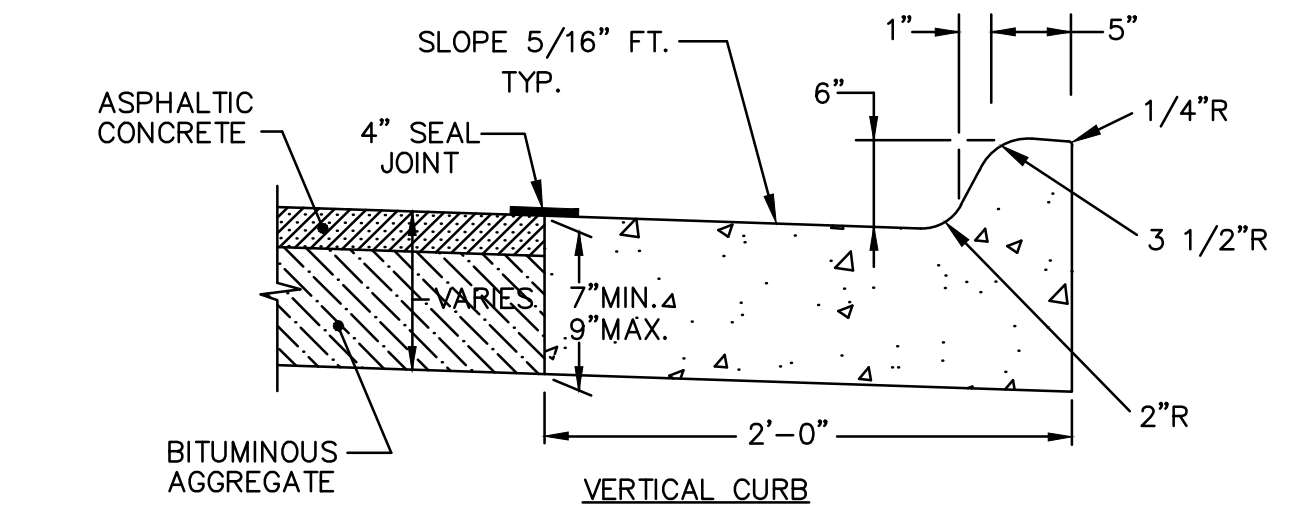

NOTE: CURB THICKNESS SHALL MATCH PAVEMENT THICKNESS.

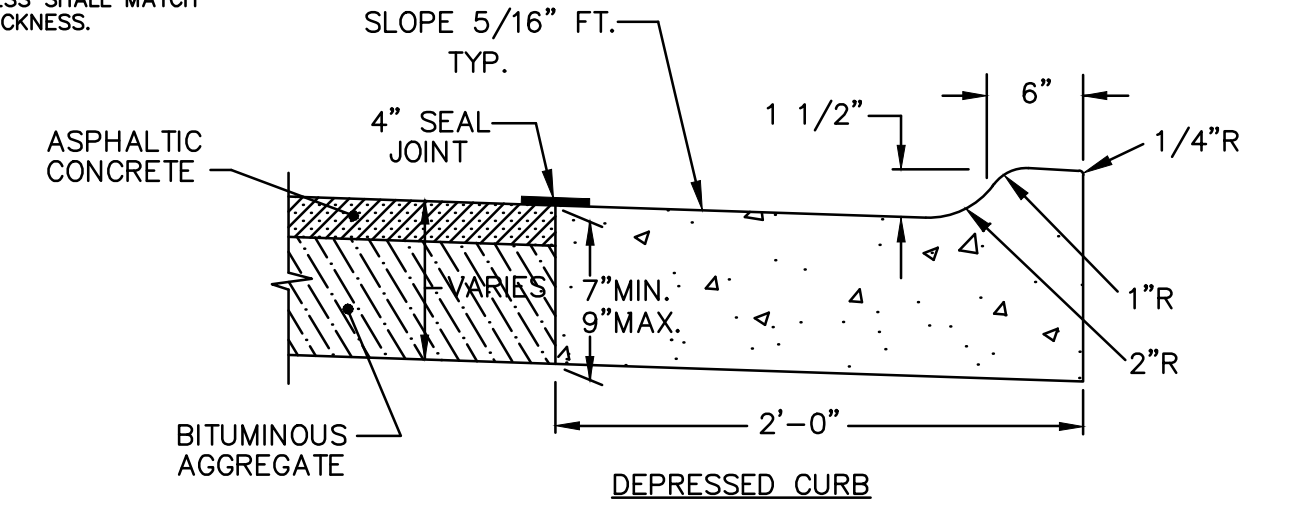

2'-0" CURB & GUTTER DETAIL FOR ASPHALT PAVEMENT
 REFERENCE ONLY NOT TO SCALE

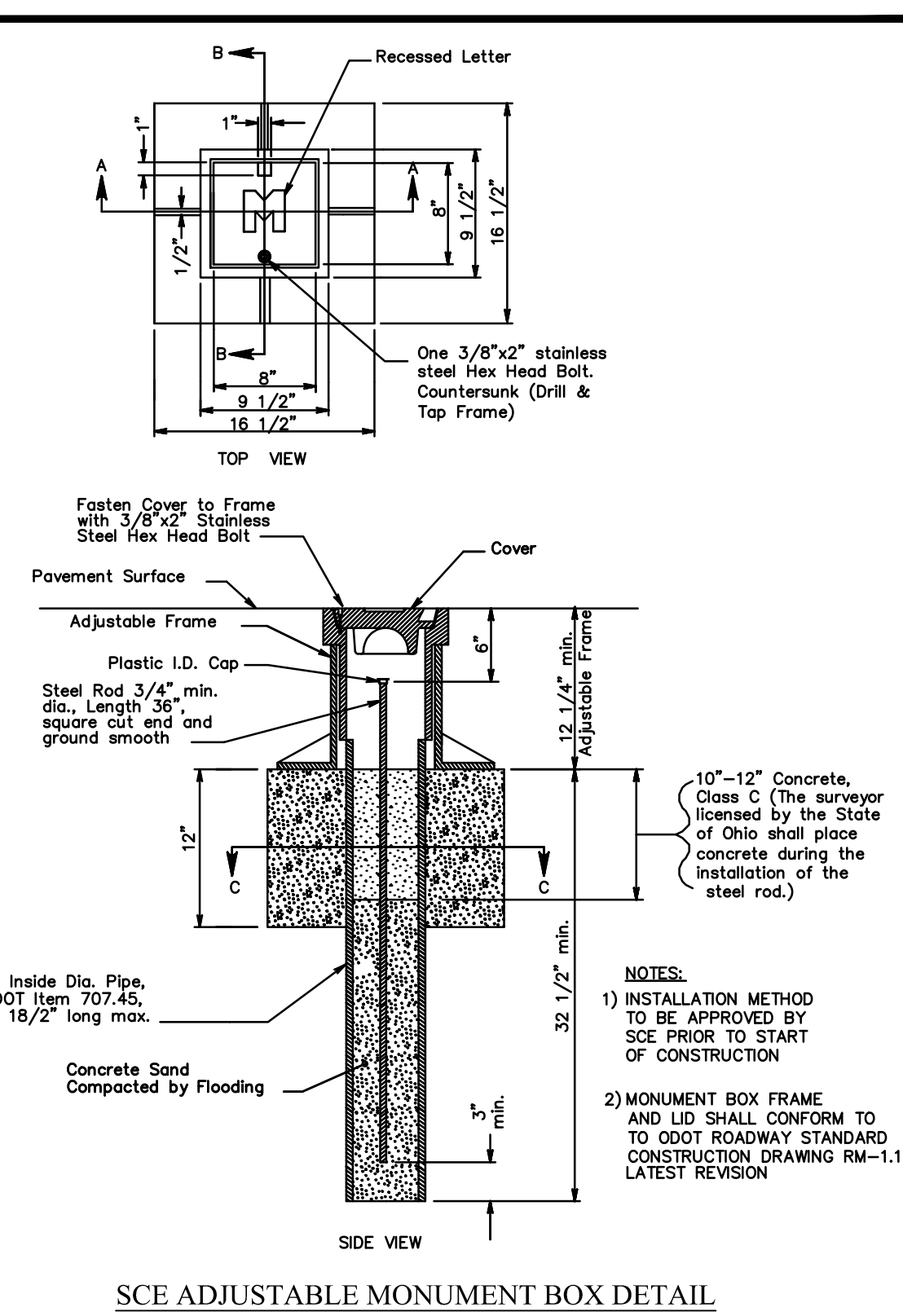

SCE ADJUSTABLE MONUMENT BOX DETAIL
 REFERENCE ONLY NOT TO SCALE

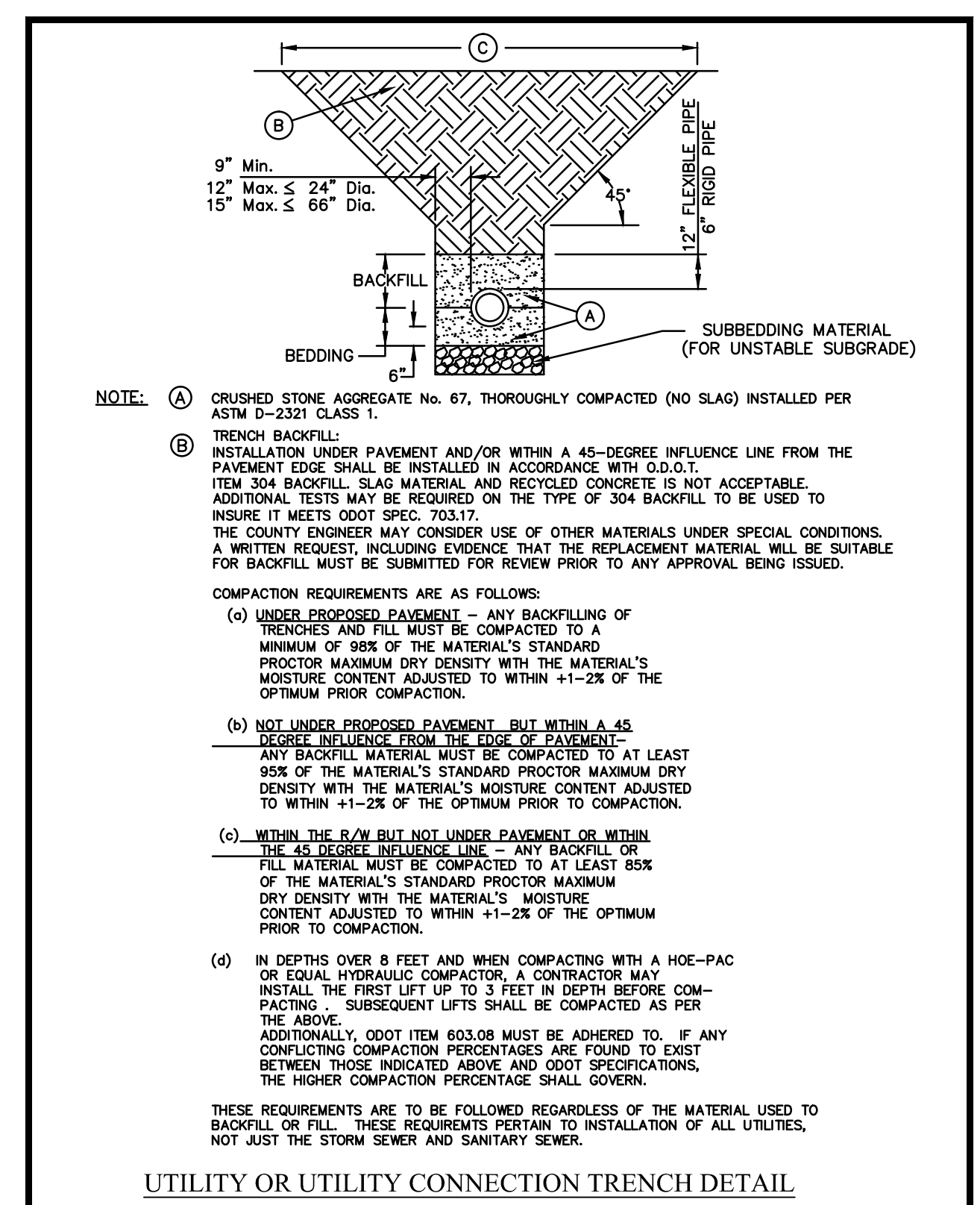

UTILITY OR UTILITY CONNECTION TRENCH DETAIL
 REFERENCE ONLY NOT TO SCALE

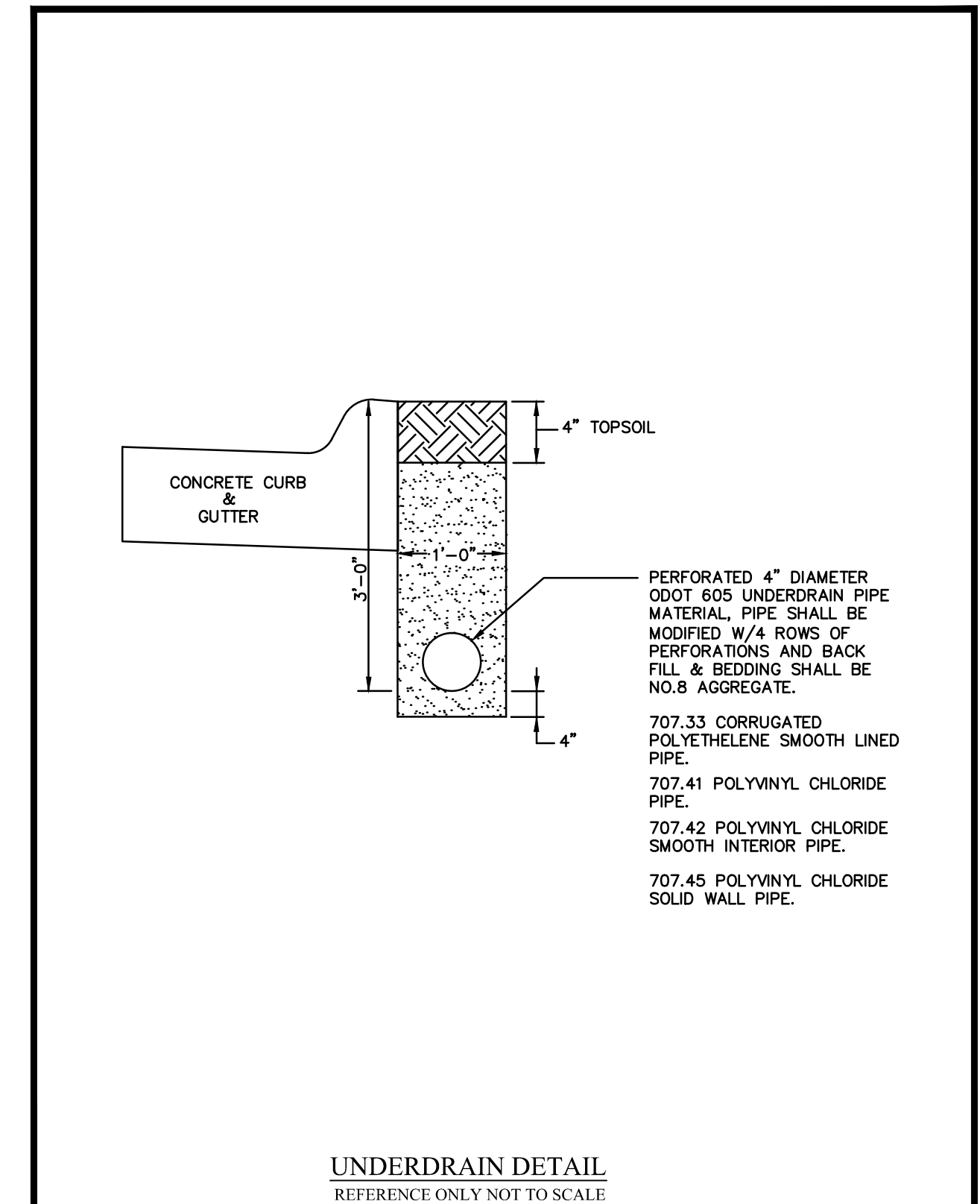

UNDERDRAIN DETAIL
 REFERENCE ONLY NOT TO SCALE

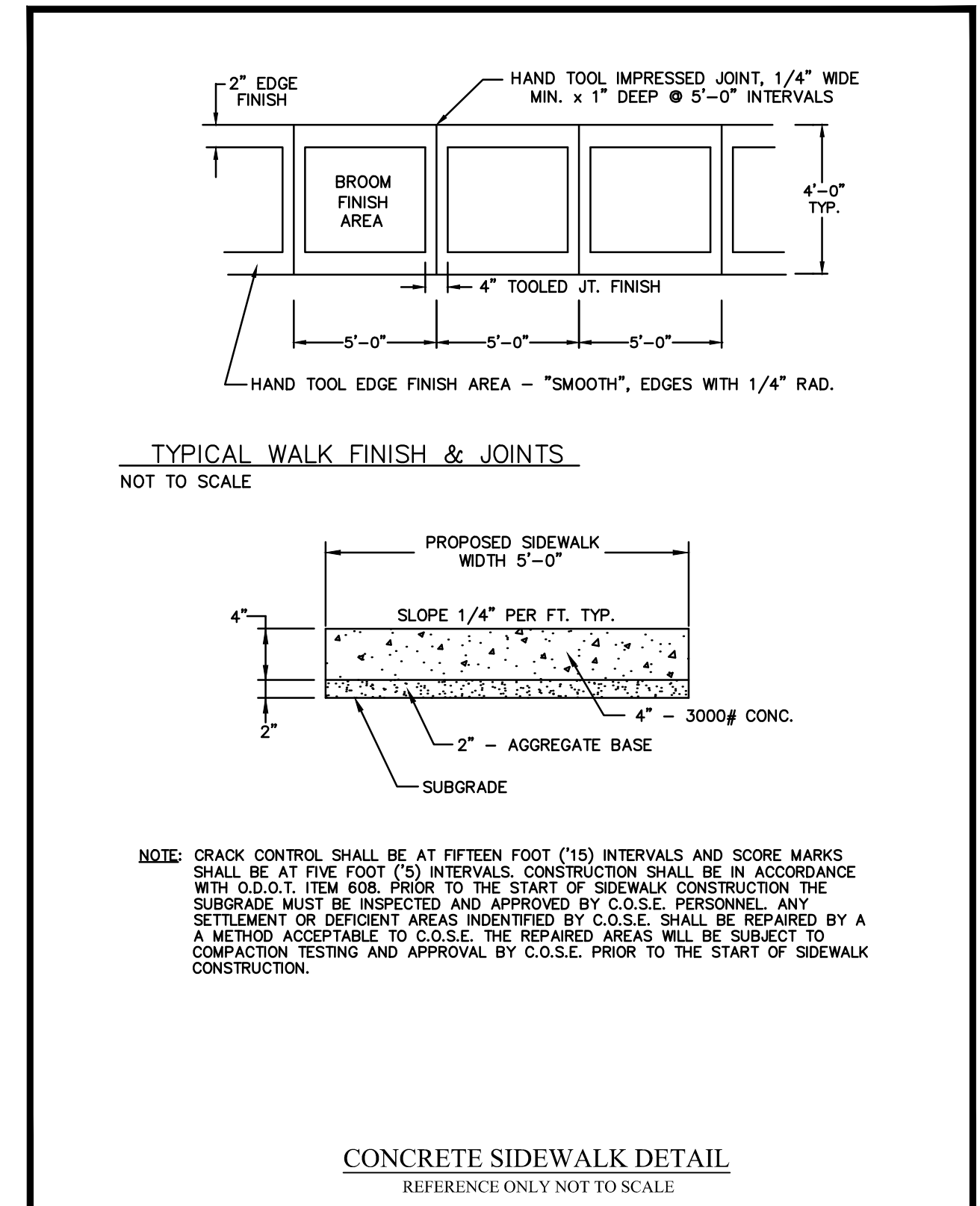

CONCRETE SIDEWALK DETAIL
 REFERENCE ONLY NOT TO SCALE

Issue Date

01-25-2016
02-05-2016
02-11-2016
02-25-2016
06-01-2016
06-29-2016
08-10-2016
09-08-2016
10-03-2016
10-10-2016
03-27-2017

HIDDEN RIDGE
 RESIDENTIAL SUBDIVISION
 DUNHAM ROAD

SITE DETAILS

C107
 Project No. 2014-226