

- STONE SIZE - TWO INCH STONE SHALL BE USED, OR RECYCLED CONCRETE EQUIVALENT.
- LENGTH - THE CONSTRUCTION ENTRANCE SHALL BE AS LONG AS REQUIRED TO STABILIZE HIGH TRAFFIC AREAS BUT NOT LESS THAN 50 FT.
- THICKNESS - THE STONE LAYER SHALL BE AT LEAST 6 IN. THICK.
- WIDTH - THE ENTRANCE SHALL BE AT LEAST 20 FT. WIDE, BUT NOT LESS THAN THE FULL WIDTH AT POINTS WHERE INGRESS OR EGRESS OCCURS.
- BEDDING - A GEOTEXTILE SHALL BE PLACED OVER THE ENTIRE AREA PRIOR TO PLACING STONE. IT SHALL HAVE A GRAB TENSILE STRENGTH OF AT LEAST 200 LB. AND A MILLEN BURST STRENGTH OF AT LEAST 130 LB.
- CULVERT - A PIPE OR CULVERT SHALL BE CONSTRUCTED UNDER THE ENTRANCE IF NEEDED TO PREVENT SURFACE WATER FLOWING ACROSS THE ENTRANCE FROM BEING DIRECTED OUT ONTO PAVED SURFACES.
- WATER BAR - A WATER BAR SHALL BE CONSTRUCTED AS PART OF THE CONSTRUCTION ENTRANCE IF NEEDED TO PREVENT SURFACE RUNOFF FROM FLOWING THE LENGTH OF THE CONSTRUCTION ENTRANCE AND OUT ONTO PAVED SURFACES.
- MAINTENANCE - TOP DRESSINGS OF ADDITIONAL STONE SHALL BE APPLIED AS CONDITIONS DEMAND. MUD SPILLED, DROPPED, WASHED OR TRACKED ONTO PUBLIC ROADS, OR ANY SURFACE WHERE RUNOFF IS NOT CHECKED BY SEDIMENT CONTROLS, SHALL BE REMOVED IMMEDIATELY. REMOVAL SHALL BE ACCOMPLISHED BY SCRAPING OR SHEEPING.
- CONSTRUCTION ENTRANCES SHALL NOT BE RELIED UPON TO REMOVE MUD FROM VEHICLES AND PREVENT OFF-SITE TRACKING. VEHICLES THAT ENTER AND LEAVE THE CONSTRUCTION SITE SHALL BE RESTRICTED FROM MUDDY AREAS.

1 SPECIFICATIONS FOR CONSTRUCTION ENTRANCE
SCALE: N.T.S.

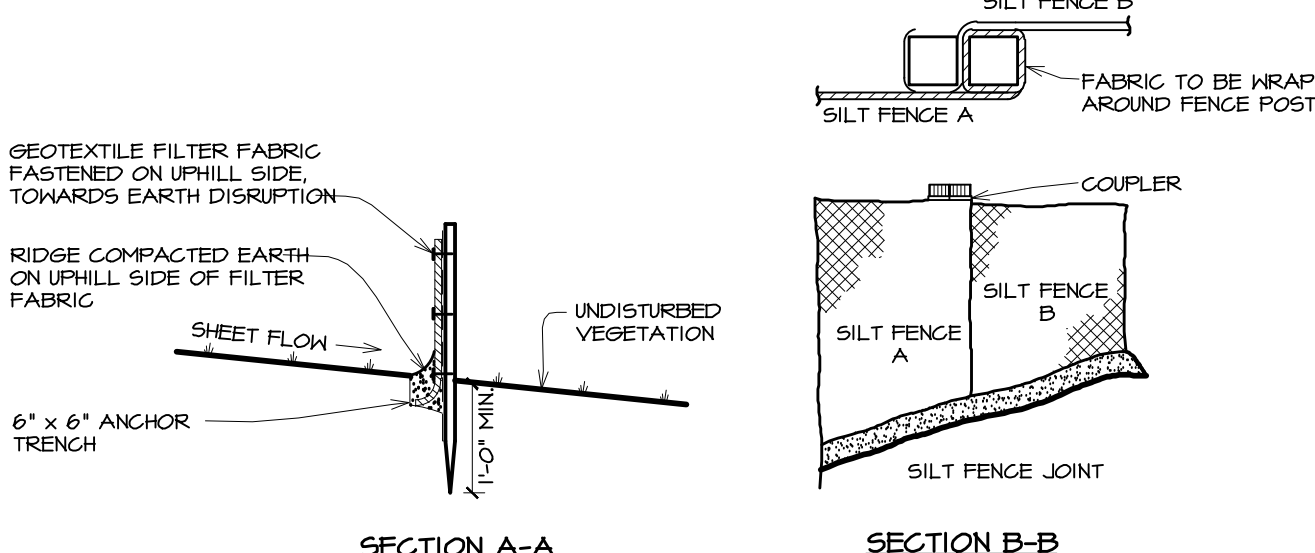

2 SILT FENCE
SCALE: N.T.S.

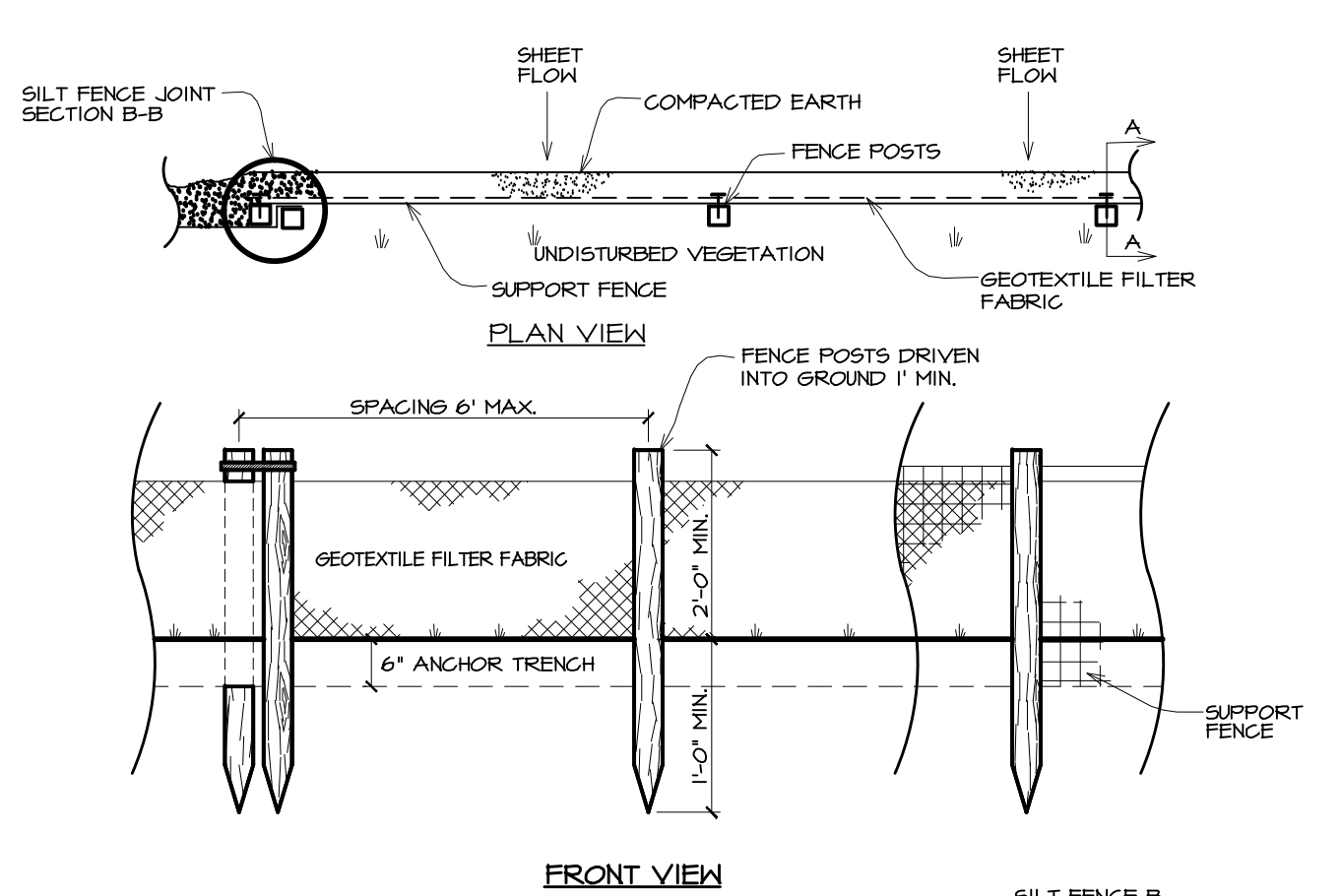
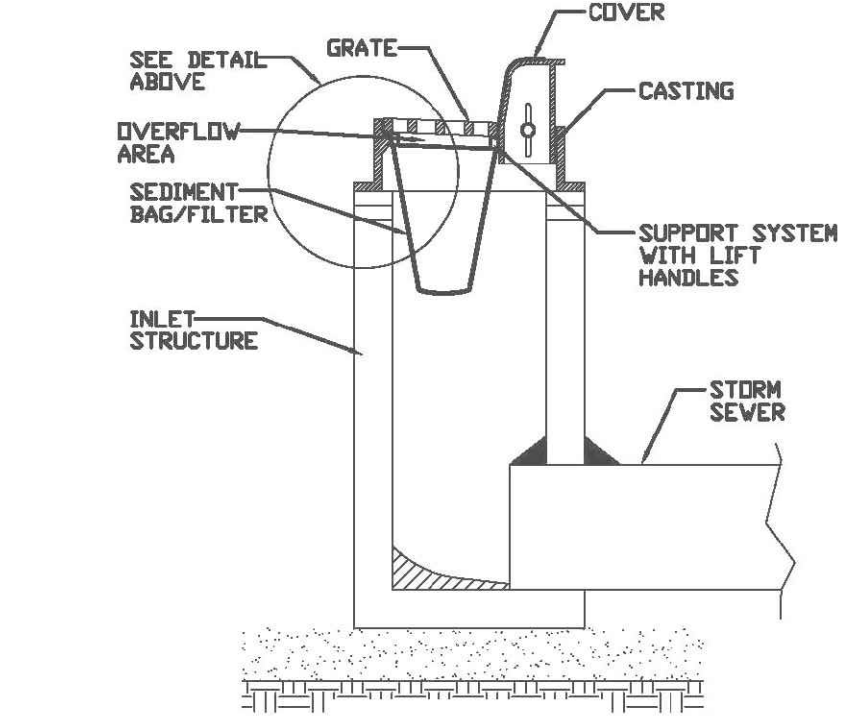
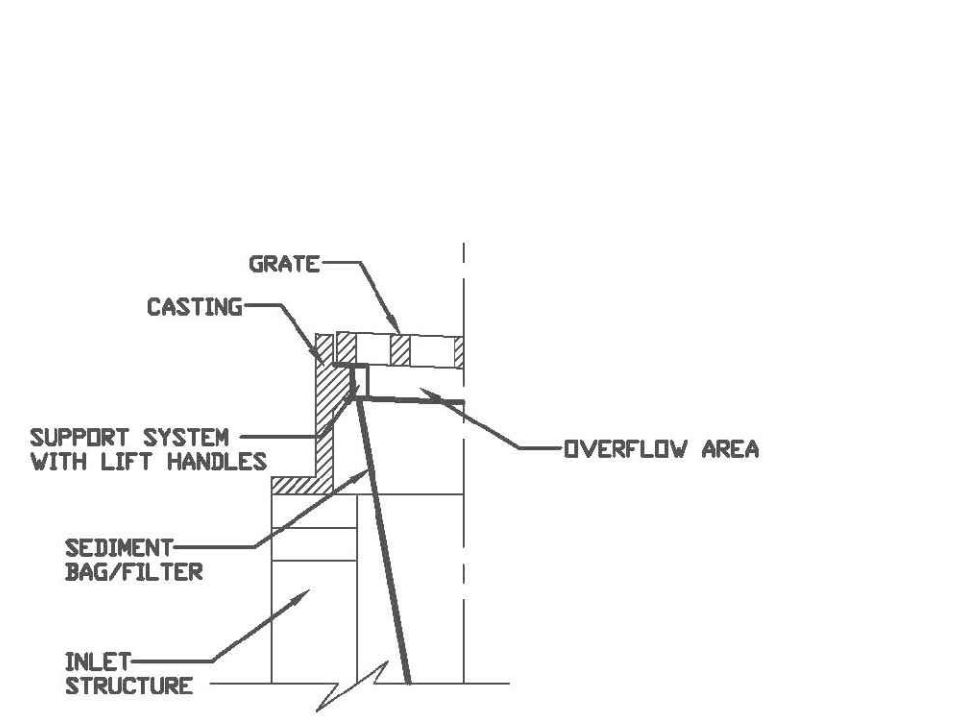

3 INLET PROTECTION
SCALE: N.T.S.

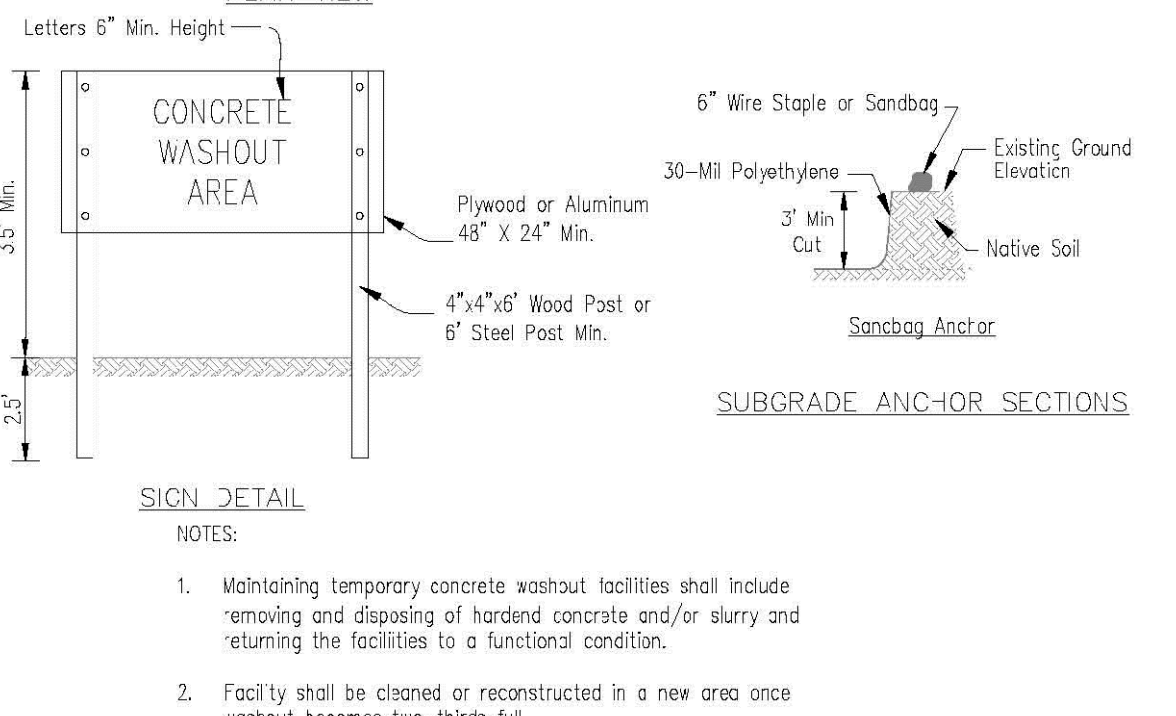
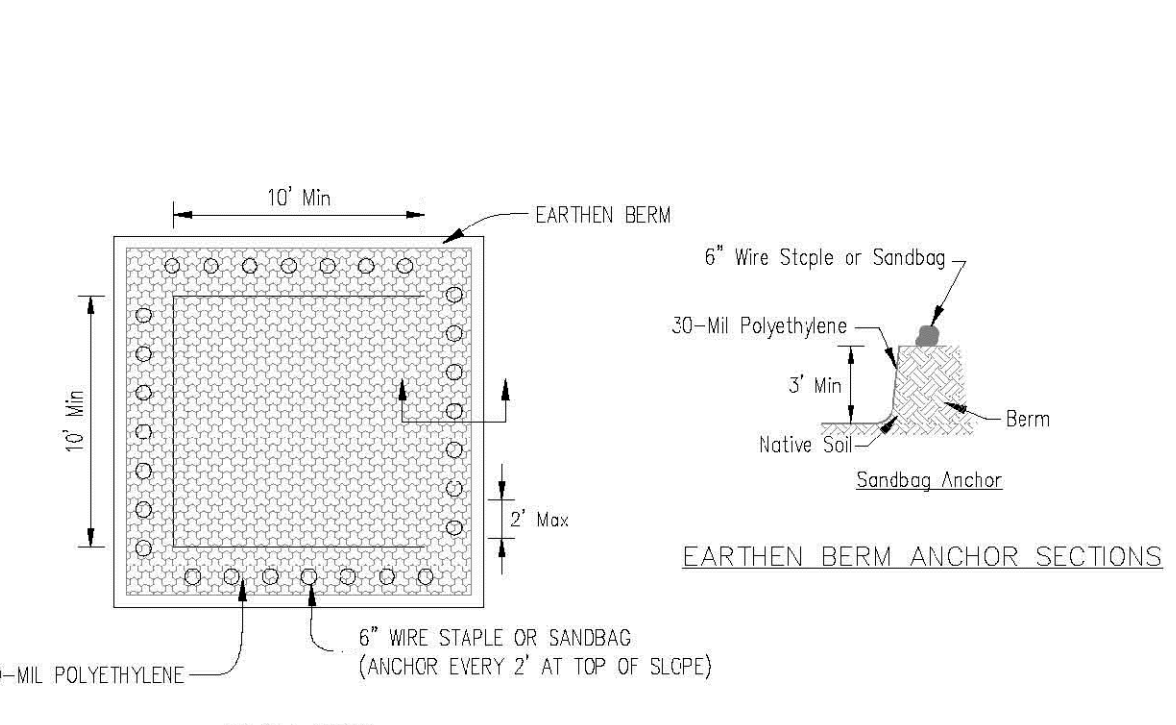

4 CONCRETE WASHOUT AREA
SCALE: N.T.S.

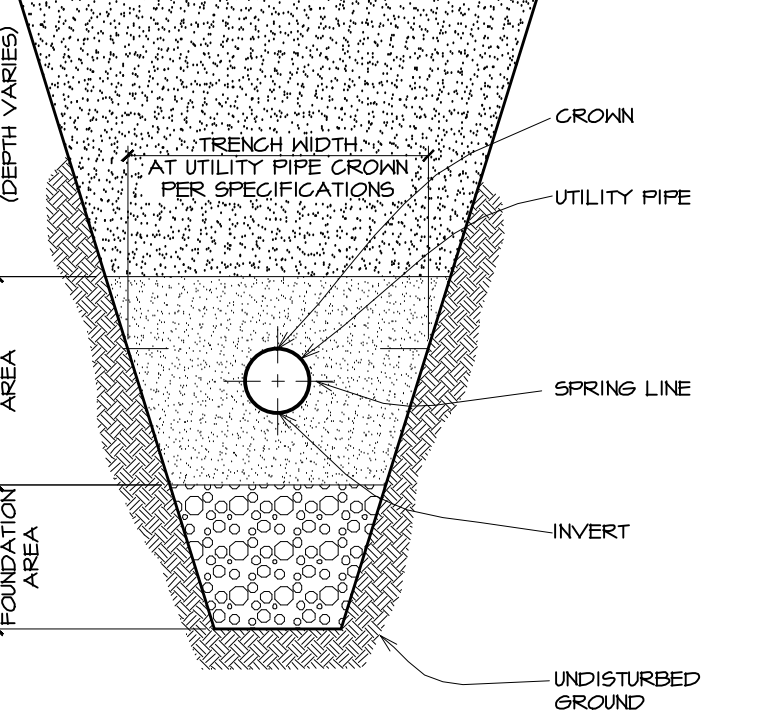

5 UTILITY TRENCH
SCALE: N.T.S.

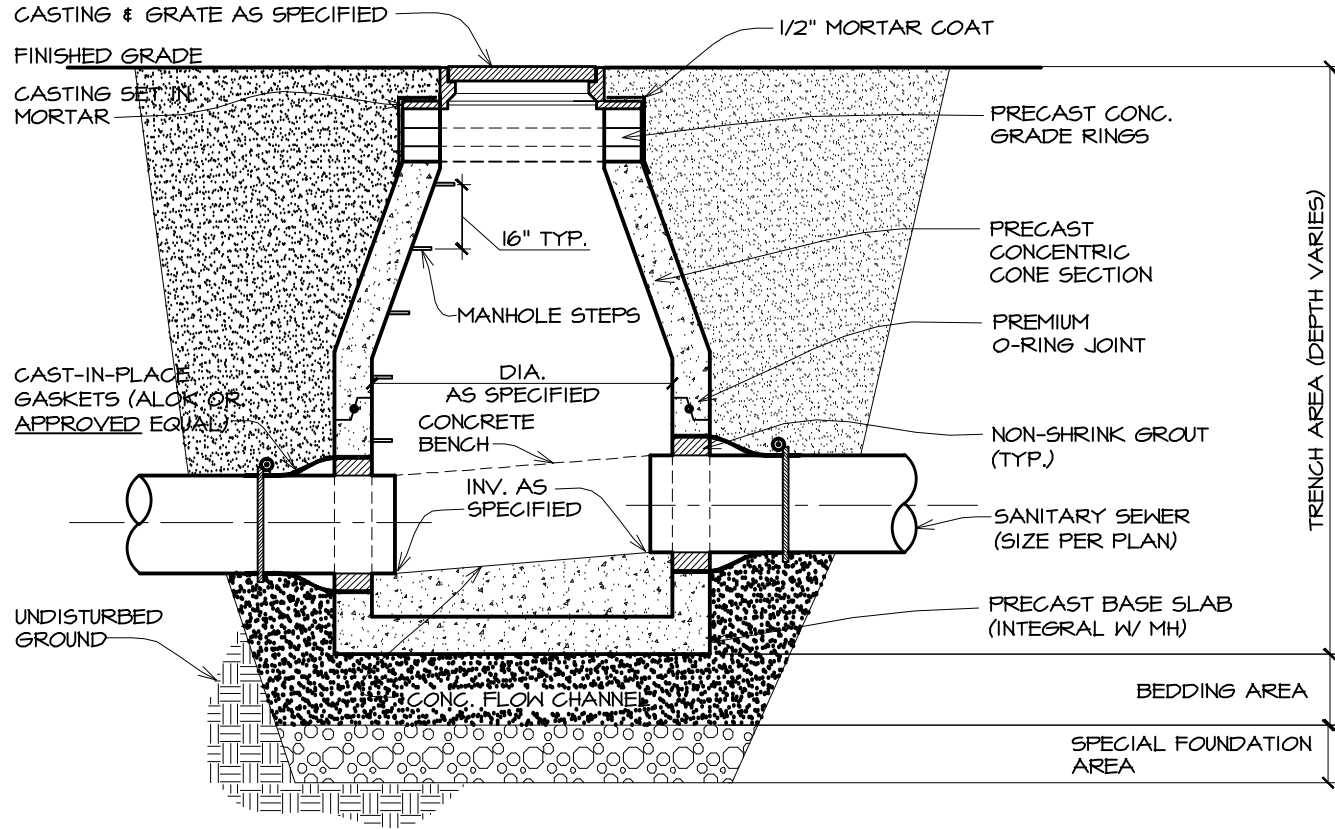

6 SANITARY MANHOLE
SCALE: N.T.S.

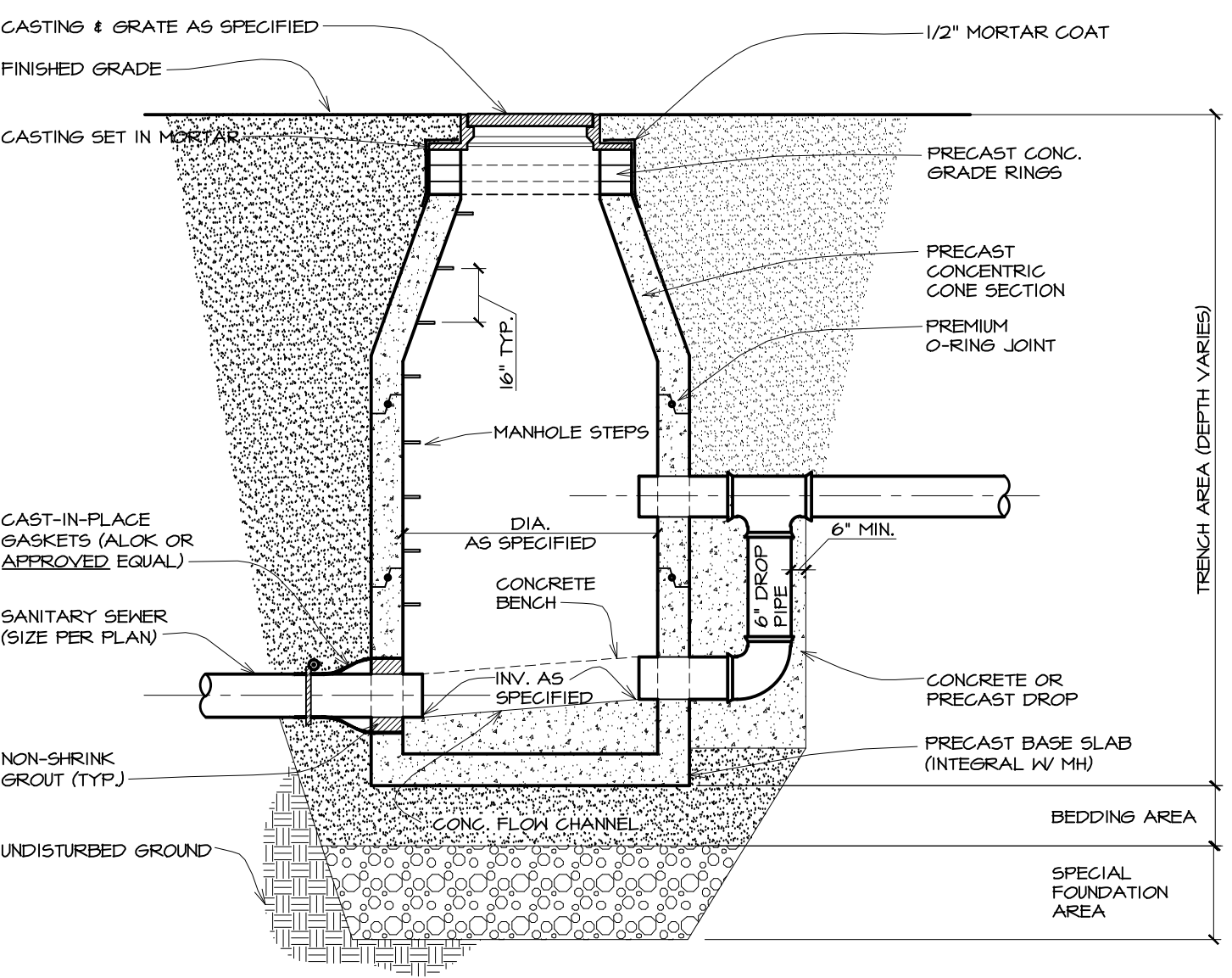

7 SANITARY DROP MANHOLE
SCALE: N.T.S.

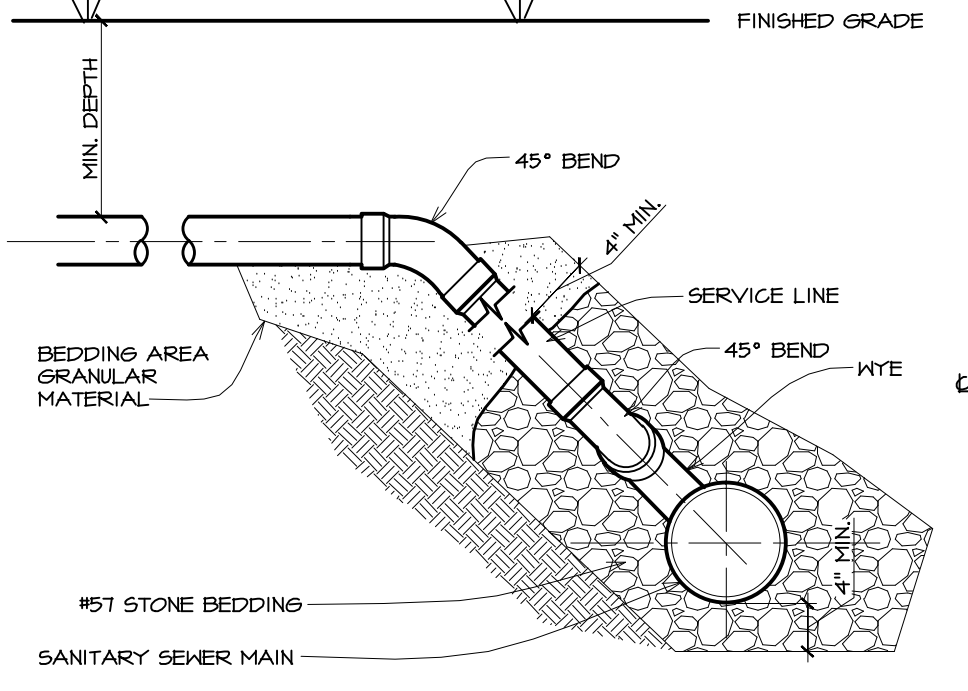

8 MAIN LINE RISER
SCALE: N.T.S.

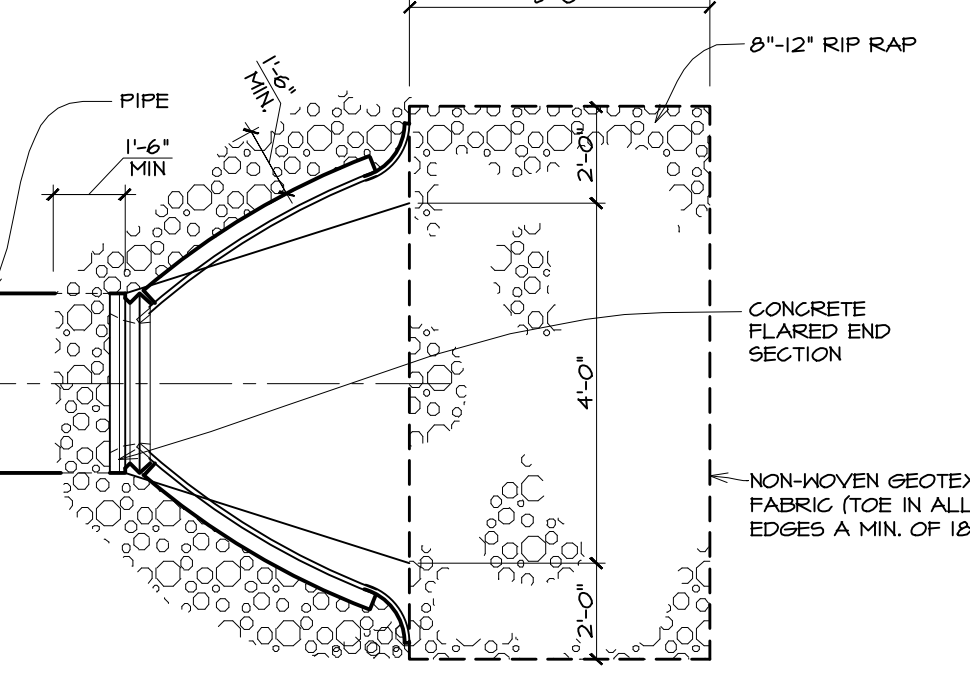

9 FLARED END SECTION DETAIL
SCALE: N.T.S.

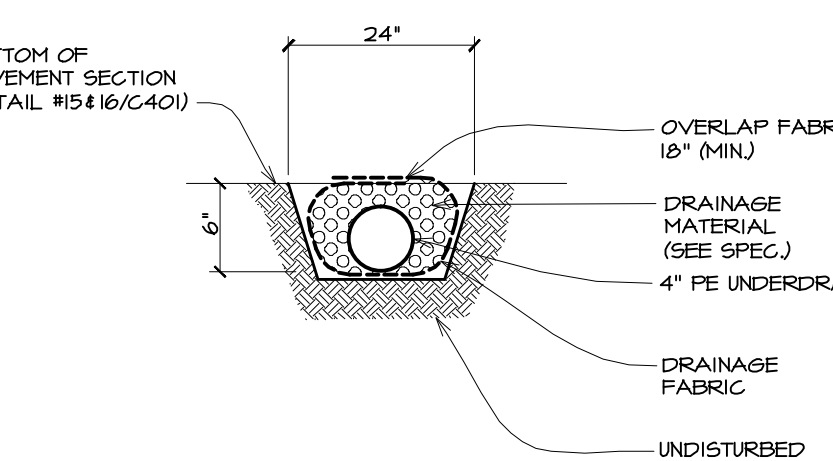

10 PAVEMENT UNDERDRAIN TRENCH
SCALE: N.T.S.

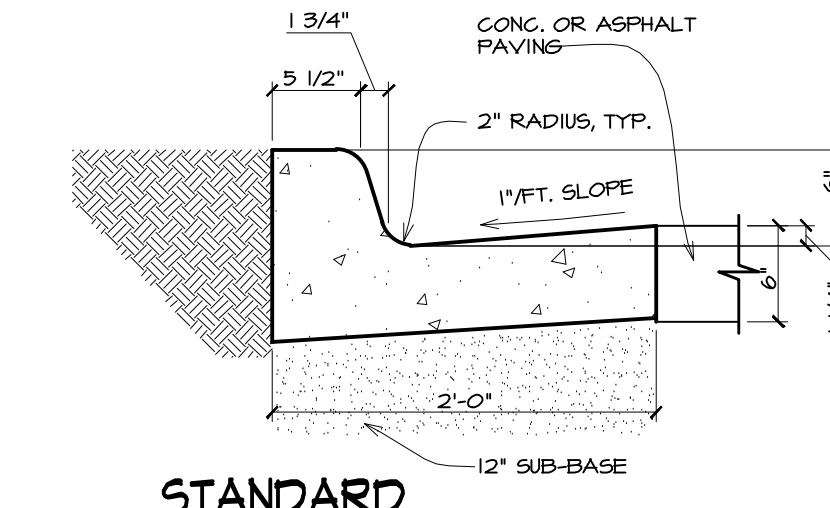

11 STANDARD CURB/GUTTER
SCALE: N.T.S.

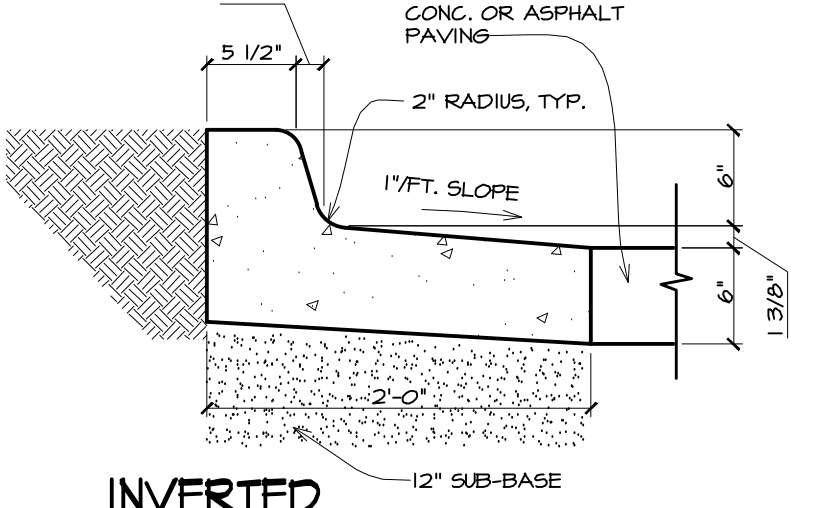

12 INVERTED CURB/GUTTER
SCALE: N.T.S.

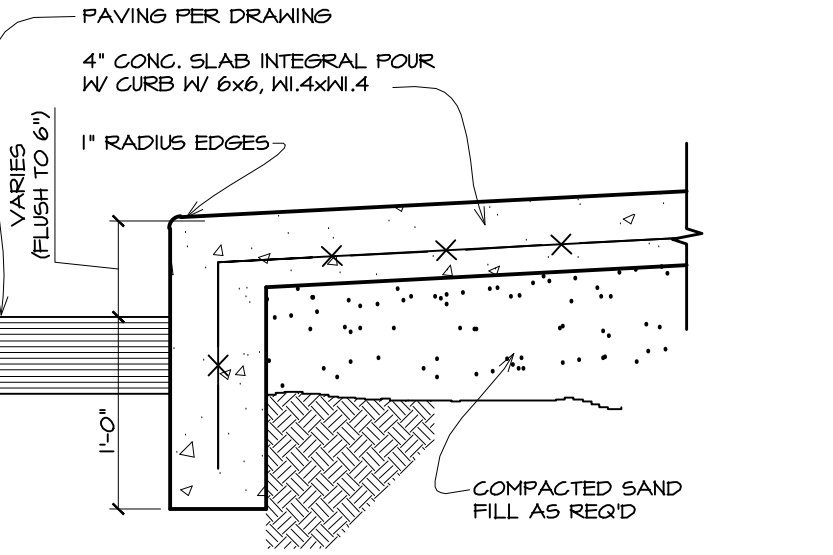

13 SIDEWALK EDGE
SCALE: N.T.S.

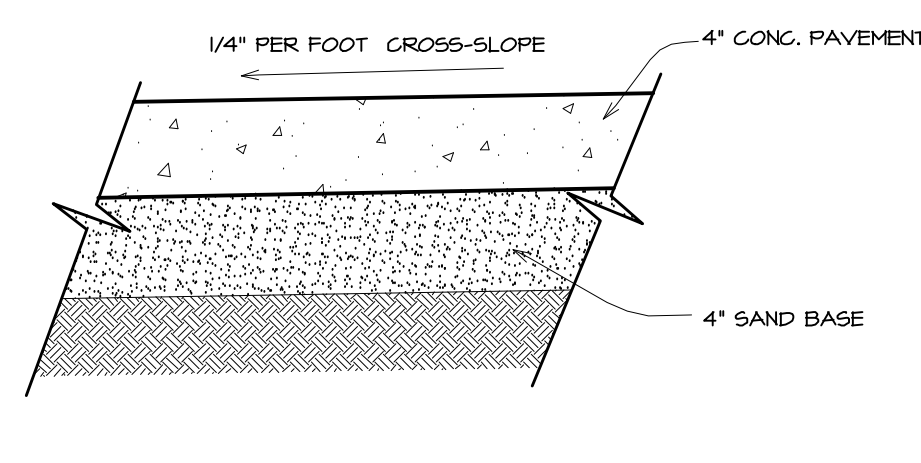

14 CONCRETE SIDEWALK
SCALE: N.T.S.

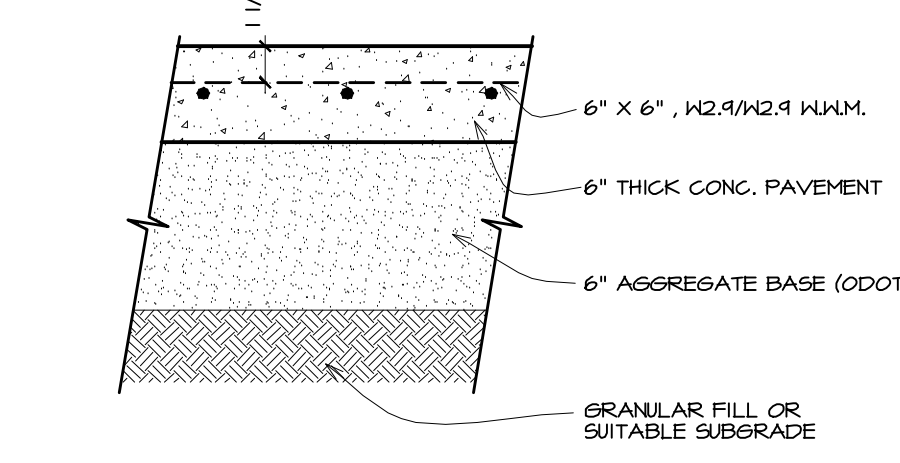

15 CONCRETE PAVEMENT SECTION
SCALE: N.T.S.

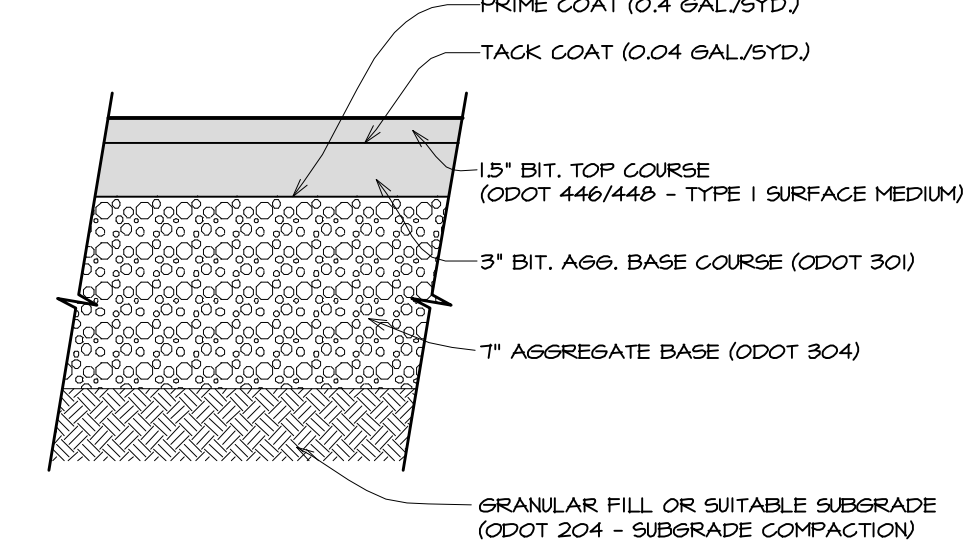

16 STANDARD BITUMINOUS PAVEMENT SECTION
SCALE: N.T.S.

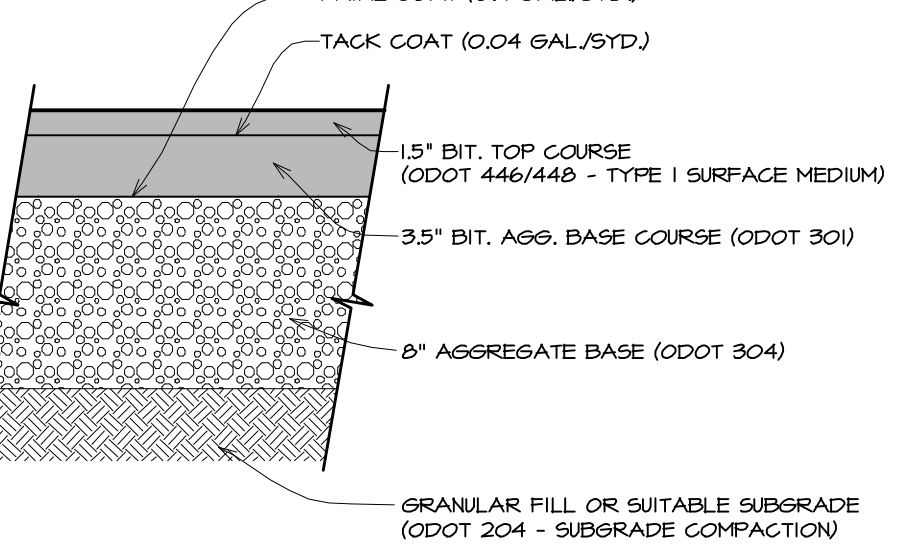

17 HEAVY DUTY BITUMINOUS PAVEMENT SECTION
SCALE: N.T.S.

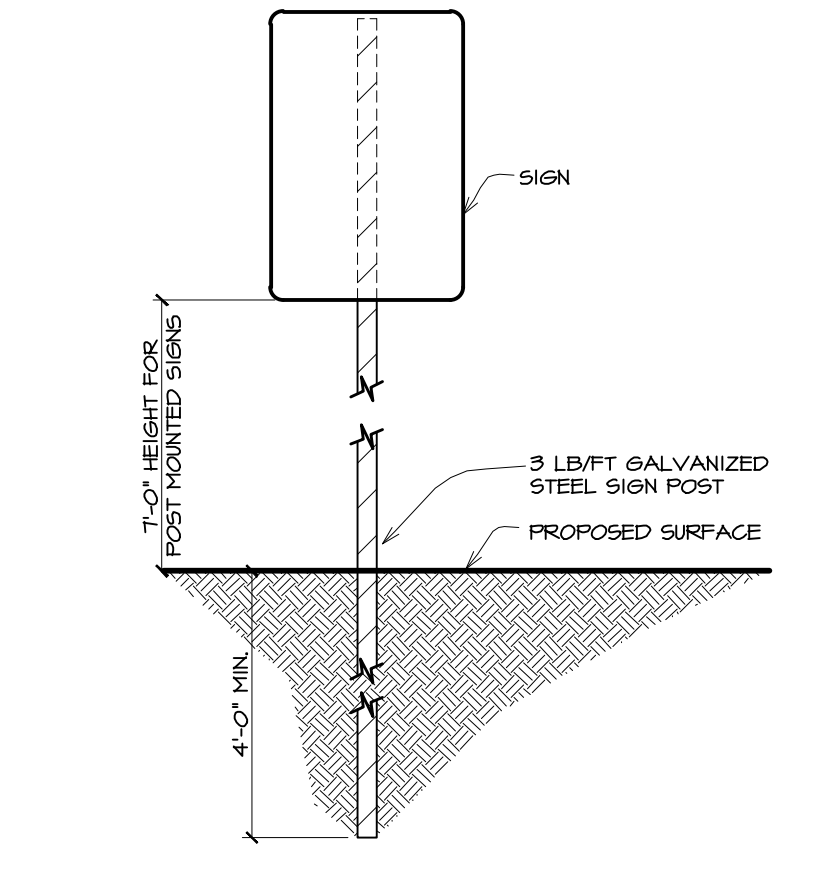

18 SIGN MOUNTING
SCALE: N.T.S.

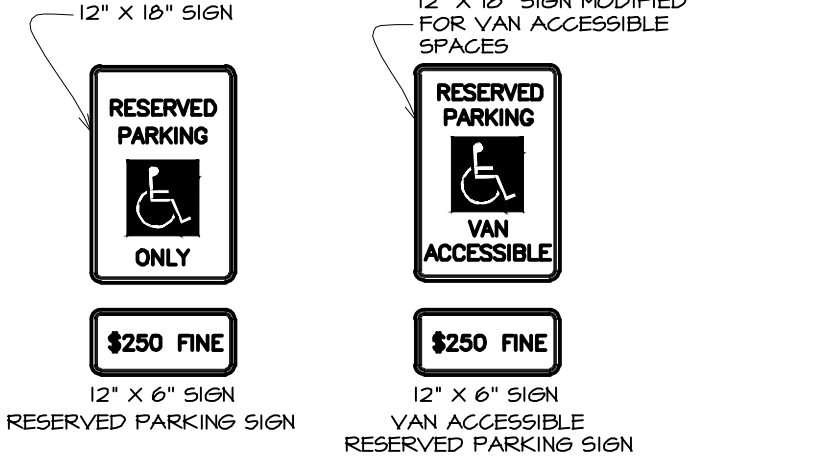

19 BARRIER FREE SIGNS
SCALE: N.T.S.

ARCHITECTS • CIVIL ENGINEERS

paradigm design

550 3 MILE N.W.
SUITE B
GRAND RAPIDS, MI 49544

PHONE (616) 785 - 5656
FAX (616) 785 - 5657
WEB PARADIGM.AE.COM

PROJECT

GFS MARKETPLACE

BILL M. MADLOCK, P.E.
OH - REGISTRATION #E-64742
EXP. DATE 1/23/2012

COPLY TOWNSHIP

TEMP 120 ROTHROCK ROAD
AKRON, OH

BLDG OWNER:

GFS MARKETPLACE REALTY FIVE, LLC

P.O. BOX 1812
GRAND RAPIDS, MI

RELEASE DATE

2-6-12 IMPROVEMENT PLAN REVIEW
4-3-12 REV. PER IMPROVEMENT PLAN COMMENT
4-23-12 OWNER REVIEW
4-27-12 FOR PERMITS & CONSTRUCTION
5-21-12 FOR PERMITS, BIDS & CONSTRUCTION

PROJECT

1105054

SHEET

C401